

# **TARM 2000** S E R I E S

## **WOOD - FIRED GASIFICATION BOILERS**

### **Installation and Operation Manual**

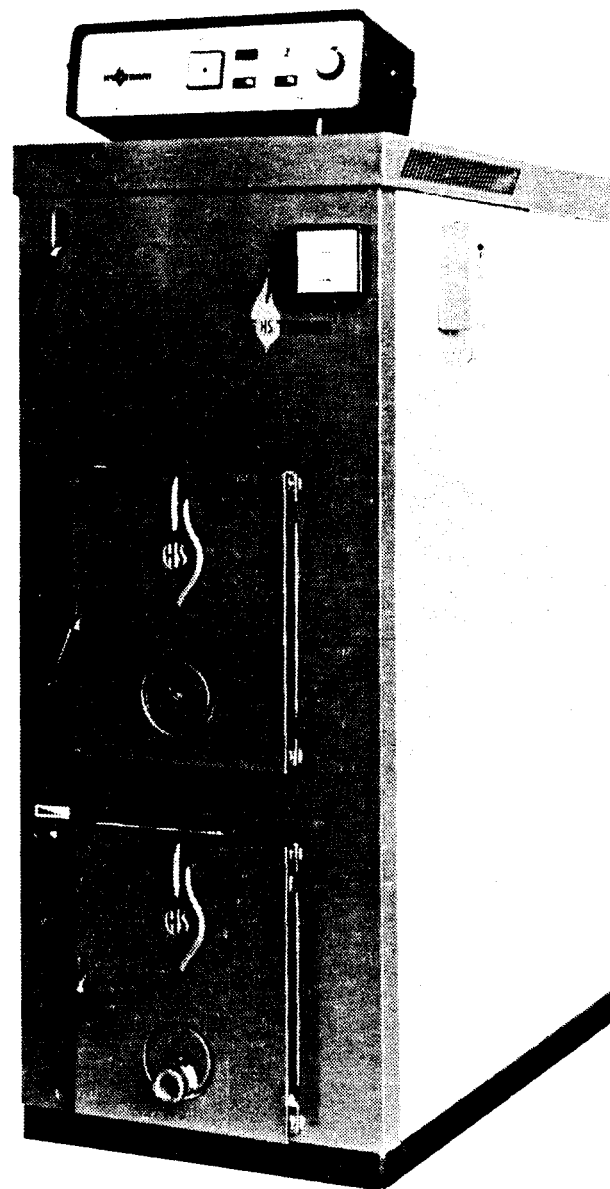

***SAVE THESE INSTRUCTIONS!***

**IMPORTANT INFORMATION - PLEASE READ THIS PAGE CAREFULLY !**

This boiler has a limited warranty, which appears on the inside back cover of this manual. To validate your warranty, detach the prepaid postcard, fill in the information requested and return the card to Stoveworks Corporation. The serial number is under the front top jacket panel.

General Information

Please read the literature enclosed by the manufacturer with the various accessory devices. These devices are warranted by the manufacturer, NOT by Stoveworks Corporation. These accessory devices must be installed and used according to the recommendations of the manufacturer.

All boilers must be installed in accordance with national, state and local plumbing, heating and electrical codes and the regulations of the serving electric, water and gas utilities.

**All systems should be designed by competent contractors, and only persons knowledgeable in the layout and installation of heating systems should attempt installation of any boiler.**

It is the responsibility of the installing contractor to see that all controls are installed correctly and operating properly when installation is complete.

Please read carefully Section VIII, B., "Service and Maintenance". Failure to protect your boiler from condensation during the warmer months MAY VOID YOUR WARRANTY!

Homeowners should read and familiarize themselves with BOILER OVERHEATING and PROCEDURES IN EVENT OF POWER FAILURE.

Do not use gasoline, kerosene or other flammable liquids to start or maintain solid-fuel fires in your boiler, or serious burns and property damage may result.

Do not store any combustibles, including fuel for the boiler, within the fire clearances specified below in "Installation Information". Keep fuel clear of the fuel-loading and ash-removal access areas.

**WARNING:** This boiler is designed to burn wood. Both hard and soft woods may be used, but under no circumstances should you burn coal or small pieces of wood or wood waste that can fall through the gap in the firebrick.

Installation Information

The boiler must be connected to a tile-lined masonry flue or other approved chimney. No other appliance should be connected to this flue. Consult your local building inspector for the chimney requirements, and install the boiler in accordance with all applicable codes.

The boiler requires adequate fresh air supply for efficient and safe operation. For more information refer to NFPA standard #31.

Boiler must be positioned to provide minimum clearances from combustibles or combustible surfaces as follows: LEFT AND RIGHT SIDE 6"; TOP AND REAR-18"; FRONT-36".

There must be a minimum clearance of 18" between smoke pipe and all combustible surfaces.

Clearance to hot water pipes is 1 inch.

Use 5 turns of TEFLON tape to seal all threaded connections.

When references are made to tapping numbers please refer to page 4.

Do NOT use self-contained, non-electric zone valves in the zone controlled by the overheat control.

Installation must conform to ANSI / NFPA standard #211

MINIMUM REQUIRED FLUE SIZE--8" X 8" TILE OR 7" ROUND  
MINIMUM DRAFT---.05 IN/WG DURING NORMAL OPERATION

PACKING LIST--- TARM 2000 SERIES BOILERS

PLEASE UNPACK THE CONTENTS OF THE BOILER BODY AND THE THREE (3) BOXES CAREFULLY, AND CHECK OFF THE FOLLOWING ITEMS ON THE LISTS BELOW:

A complete 2000 series boiler, as shipped from our warehouse, consists of four (4) pieces, as follows;

1. Boiler body

- - - In the boiler body you should find;

- Refractory combustion chamber (installed)
- Ash removal pan.
- Ash removal/scrapper tool.
- Cleaning Brush
- By-pass damper lever (installed)
- Installation manual
- 24 volt draft fan (2002) -- 110 volt fan (2004)
- Control panel with immersion well (2002 only)

2. Jacket box

- One front panel
- Two side panels
- One rear panel
- Two top panels (front and rear)
- Special door gasket set consisting of:
  - 2 pcs large flat gaskets & 2-pcs of rope gasket 57"

3. Door box

- Loading door
- Ash door
- By-pass lever bakelite knob (larger)
- Secondary air bakelite knob

4. Safety control package

- Boiler pressure relief valve (WATTS 174A, 30 psi)
- High temperature limit (Honeywell L4008B)
- Immersion well 3/4 in
- Pressure/Temperature Gauge
- Honeywell 8124M Aquastat w/3/4 well (2004 only !)
- 24 Volt transformer (2002 only)

Please contact your dealer immediately if any of the above items are missing! Stoveworks Inc. reserves the right to substitute equivalent equipment for any of the controls and accessories specified above.

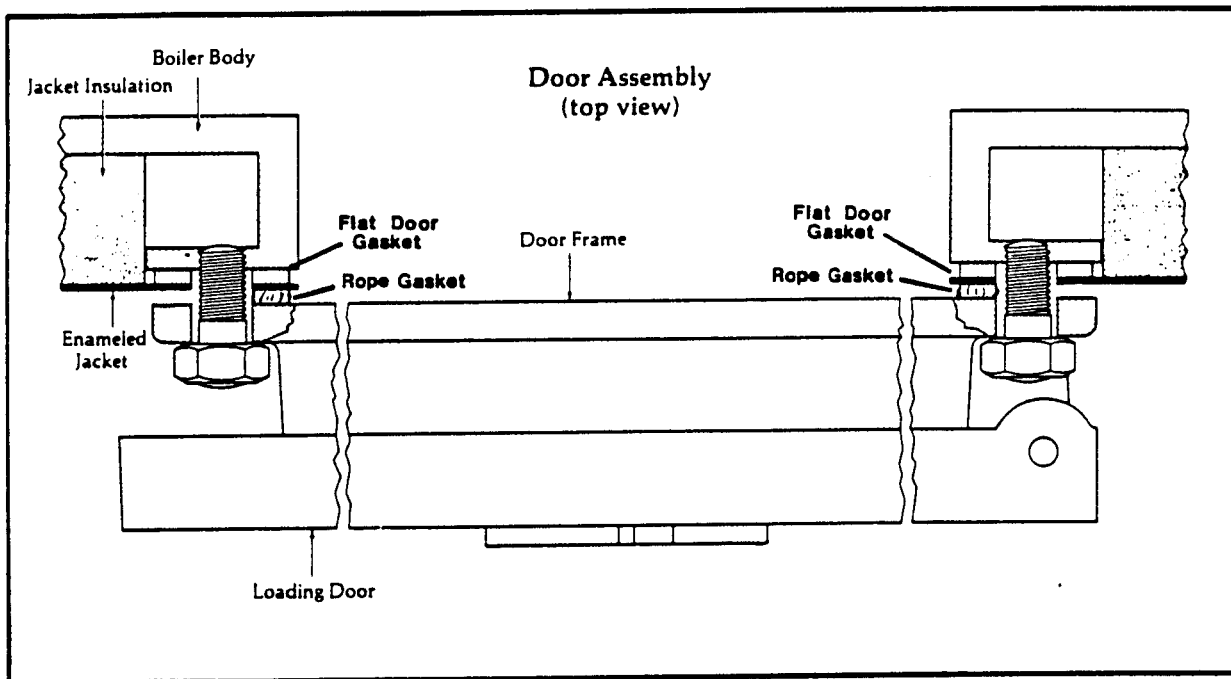

5) With the flat gaskets on the door flanges, put the front jacket panel in place. Feed the secondary air control lever through the slot in the jacket. Install the door on the frame, but do not tighten the nuts yet. Take the rope gasket supplied and install it from the inside, around the perimeter of the door as shown in the photo. The rope gasket must be placed between the door and jacket (not between the jacket and boiler body). The nuts should be far enough onto the studs so the gasket can be easily pushed into place but will not fall out. The ends of the rope should overlap. The aim is to create an air tight seal when the nuts are tightened fully.

**Note:** If the boiler will be equipped with the optional electric back-up elements and sequencers, refer to the TARM 2002 Electric Package Instruction Sheet before installing the left side jacket panel.

D. Control Panel and Fan Assembly

Note: All piping connections must be made with at least 5 turns of teflon tape.

- 1) Install the 3/4" immersion well (found in the safety package box) in tapping # 27 on top of boiler.
- 2) **(2002 only)** Install the 1/2" control panel immersion well (found in the control panel box) in tapping #21 on top of boiler.  
**(2004 only)** Plug Tapping #21

3) Feed the By-pass lever through the slot in the upper left hand corner of the front jacket panel and thread the bakelite knob on the front of the rod. Attach the rod to the by-pass damper as shown in the photo. The by-pass lever is adjusted at the factory, but should be checked on the job, as correct adjustment is essential for proper combustion. To check adjustment, push the by-pass knob in and down, It should lock into place on the front bracket with a firm push. If the stop on rod is engaged on the front bracket, but the handle still has front to back play; or if the handle will not push in far enough to engage the stop, the by-pass must be adjusted. To do so, loosen the nut at the rear of the rod; and rotate the rod to tighten or loosen the adjustment. To complete the adjustment, make sure the welded stop rod is pointed downward, and tighten the locknut.

- 4) Place the 2" thick insulation material (found in the jacket box) on top of the boiler, matching cutouts with the tappings.
- 5) Remove the metal bracket protecting the adjusting screw and blower flange. Using the same screws attach the blower to the flange.
- 6) Attach the Honeywell L4008B Aquastat (supplied in the safety package) to the right side of the boiler with sheet metal screws, as shown in the photo. Feed the temperature probe through the plastic knockout plug and insert in the 3/4" immersion well (tapping # 27),

NOTE: If the TARM 2000 will be installed as the only boiler in the system, or if it will be installed in a "Series" or "Automix" system, this Aquastat is used as the boiler overheat control, and is wired to operate the largest zone if the boiler temperature exceeds the setting on the aquastat. In a "Parallel" system, this aquastat serves to operate the circulator between the two boilers. See section III and the wiring instructions for more information.

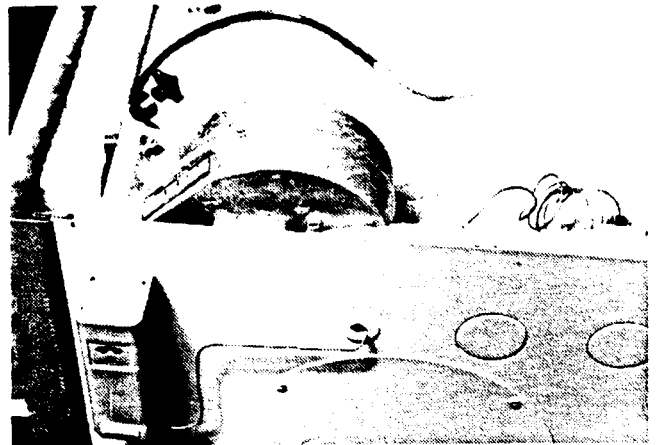
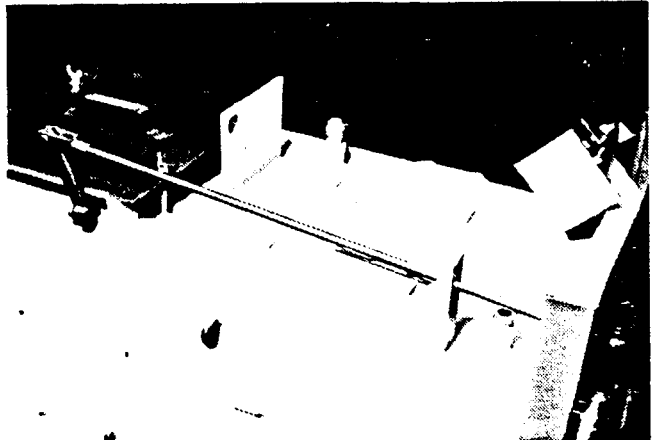

## II. DOMESTIC HOT WATER SYSTEM

A tankless coil for heating domestic hot water is available as a factory installed option on the TARM 2000 boiler or it may easily be added after the boiler is already installed. For ready access to the coil; the cover plate on the jacket is removable.

Pipe the cold water to tapping #15, and hot water from tapping #14 (or vice versa). It is desirable to install unions external to the boiler in both the cold and hot water lines.

NOTE: If a separate hot water heater will be used to heat domestic water during the warmer months, please follow precautions for preventing corrosion described in Section IV of this manual. Cold water must be piped separately to the separate water heater, not through the coil in the TARM boiler. COLD WATER MUST NOT FLOW THROUGH THE TARM DOMESTIC COIL IF THE TARM BOILER IS UNHEATED! CONDENSATION AND CORROSION OF THE BOILER BODY CAN RESULT IF WATER FLOWS THROUGH THE UNHEATED BOILER.

Install the Pressure Relief Valve (WATTS 3L, 125 psi) in a tee on the cold water supply to the tankless coil, there must be no shut-off valve or check valve between the relief valve and the tankless coil. The Relief Valve Discharge Line MUST BE PIPED TO WITHIN 6" OF THE FLOOR NEAR A DRAIN, AND MUST BE 3/4" PIPE WITH NO REDUCTION. IF THIS VALVE OPERATES, HOT WATER WILL BE DISCHARGED. IT SHOULD BE PIPED TO AN OPEN DRAIN; SO THAT THIS WATER WILL NOT DAMAGE THE ROOM IN WHICH THE BOILER IS LOCATED.

NOTE: TO PREVENT THE POSSIBILITY OF A PERSON SUSTAINING SERIOUS BURNS FROM DOMESTIC HOT WATER, A TEMPERING VALVE (WATTS 70A OR EQUIV.) MUST BE INSTALLED TO PROTECT AGAINST DANGEROUSLY HIGH DOMESTIC WATER TEMPERATURES.

NOTE: In certain areas, existing water supplies may have a high mineral content. This will lead to liming of the coil over time, depending on the mineral content of the water and the amount of water passing through the coil. Coils should be cleaned as soon as there is any indication that the hot water supply is being restricted. Coils are cleaned with hydrochloric acid-- CLEANING THE COIL IS A DANGEROUS PROCEDURE THAT SHOULD BE ATTEMPTED ONLY BY A QUALIFIED AND EXPERIENCED PERSON.

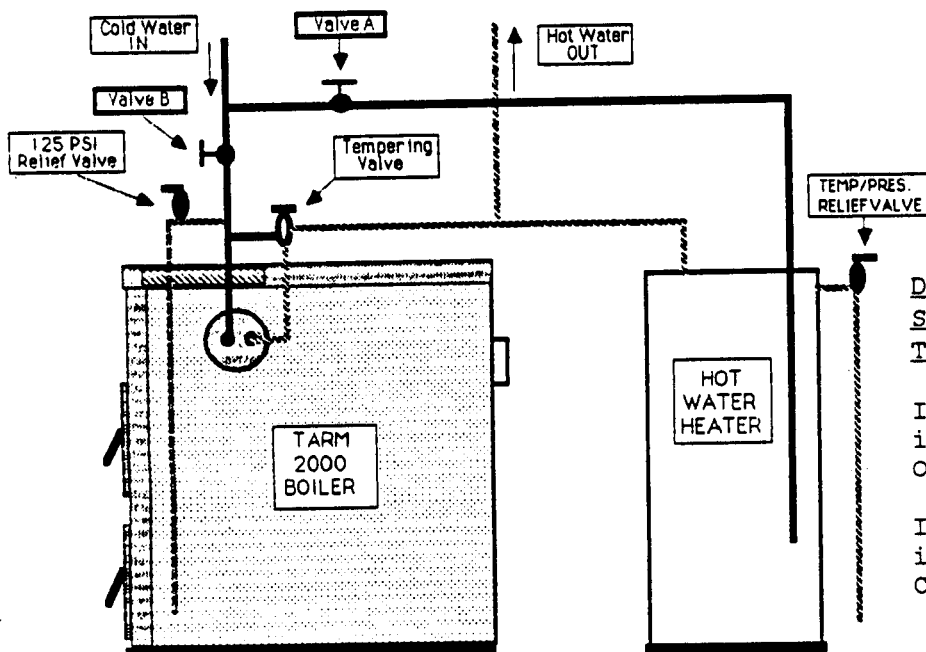

### DOMESTIC HOT WATER PIPING WHEN A SEPARATE DHW HEATER IS USED IN THE SUMMER MONTHS

IN SUMMER: (or when TARM boiler is shut down) CLOSE Valve B and OPEN Valve A.

IN WINTER: (when TARM boiler is in operation) OPEN Valve B and CLOSE Valve A.

## Parallel

When the TARM 2000 is connected in parallel with an existing oil, gas, or electrically-fired boiler, domestic water can always be heated by a wood fire regardless of whether the coil is located in the TARM 2000 or in the other boiler. Since the parallel connection provides the TARM 2000 with a larger effective reserve of water to be heated, the likelihood of boiler overheating is minimized and the system can respond more quickly to heating demand. For instructions on the parallel hookup; see page 17.

## HS Auto-Mix

The HS AutoMix, when piped as shown in the diagram, provides the most convenient and economical heating system possible using the TARM 2000 boiler.

The HS AutoMix system is a method of controlling house temperature that is different from and more sophisticated than conventional systems. In the conventional hydronic system, the temperature in the house or zone is controlled by circulating or not circulating water of a fairly high and relatively constant temperature to radiation. The thermostat used in such a system is a simple temperature-actuated switch that turns a circulator on and off. In the HS Auto-Mix system, the circulator in the radiation loop runs continuously, and the temperature of the water flowing to the house is controlled by the mixing valve, which adds varying amounts of heated boiler water to the continuously circulating water in the radiation loop. The valve is controlled automatically by a thermostat.

In an Auto-Mix system, the circulator runs constantly. Heat is always being drawn from the boiler, thus minimizing the likelihood of boiler overheating and creosote and soot formation.

The HS Auto-Mix promotes safer, cleaner and more efficient burning of any solid fuel. The AutoMix is especially important in installations with cast-iron radiation. The large volume of returning cold water from cast-iron radiation causes boiler temperature to drop suddenly and often results in poor boiler performance on solid fuel unless a mixing valve is used to keep radiation warm at all times in proportion to heating demand.

See page 18 for instructions on installing the HS AutoMix. For more information on the HS Auto-mix System contact your local HS TARM distributor.

A. TARM 2000 As Only Boiler Without Electrical Back-Up

NOTE: All interconnection wiring must be completed as per the wiring diagram, see pg. 19.

- 1) Thread a 1-1/4" pipe nipple into tapping 2, rear of boiler. Thread an AMTROL #444 (1 1/4") air purger using the inlet tapping "U", onto this nipple. DO NOT REDUCE THE FLUE SIZE UNTIL AFTER THE AIR PURGER !
- 2) Connect AMTROL #60 expansion tank to tapping "Z" on bottom of the purger (This tank is sufficient for systems up to 86 gal.capacity. For systems with greater capacity, consult your distributor.)
- 3) The other tapping "U" is used for connection to heating radiation.
- 4) Install the circulator in the return line from the heating radiation. Pipe the return into tapping 1, rear of boiler.
- 5) The circulator may be controlled by a Circulator Relay, Honeywell RA89A or equivalent. This relay should be controlled by both the room thermostat and the Hot Water Overheat Control.

NOTE: In a case where the thermostat is calling for heat and the boiler fire is out or otherwise unable to meet the heating demand of the house, the circulator will continue to run. This has the advantage of helping prevent the water in the system from freezing if the house temperature drops below 32 deg F. If subfreezing interior temperatures are anticipated, the system must be drained. As an alternative to draining the system, a mixture of heating system antifreeze and water can be used in place of normal water in the system. Such a mixture should be added only after the system is thoroughly checked for leaks. Consult your dealer for further information.

B. TARM 2000 As Only Boiler, With Electrical Back-Up

NOTE: All interconnecting wiring must be completed as per diagram, page 19.

- 1) Pipe out from the supply (tapping #2) of the TARM 2000 boiler to a 1-1/4" Tee.
- 2) Thread an AMTROL 444 (1-1/4") air purger and 1-1/4" nipple into the remaining arm of the 1-1/4" Tee. Use the inlet tapping "U" of the air purger for this connection.
- 3) Connect an AMTROL 60 expansion tank to tapping "Z" on the bottom of the air purger (This tank is sufficient for systems of up to 86 gallons capacity. For systems with greater volume, consult your distributor.)
- 4) Thread an air vent into tapping "V" on top of the air purger. Unscrew the cap on top of the vent.
- 5) The remaining tapping "U" on the air purger is used for connection to heating radiation.



D. Parallel Hookup

NOTE: All interconnecting wiring must be completed as per the wiring diagram, page 19.

NOTE: All pipe connecting the two boilers must be 1-1/4".

1) Remove existing radiation supply and return lines from the oil- or gas-fired boiler. Install nipples and pipe tees on supply and return of existing boiler. Reinstall supply and return lines.

2) Pipe out from the supply (tapping 2) of the TARM 2000 boiler to a 1-1/4" tee using an iron pipe nipple. Do not reduce pipe size!!

3) Install a HONEYWELL L4006B or equivalent Aquastat into one arm of the tee, using a 1/2" immersion well and a 1-1/4" by 1/2" bushing. This Aquastat is used as the boiler overheat control. See wiring instructions for more information.

4) Pipe from the tee installed on TARM 2000 supply to the tee previously installed on the existing boiler's return tapping.

5) If the addition of the TARM 2000 has increased the water capacity of the heating system beyond the rating of the existing expansion system, an additional expansion tank should be added to the system. Consult your distributor if in doubt about the requirements of the heating system.

6) Install piping, a flow check valve, and a circulator between TARM 2000 return (tapping 1) and the tee previously installed on the existing boiler's supply tapping. Refer to the piping schematics (page 14) for the correct direction of flow.

NOTE: The HONEYWELL L4008B remote-bulb aquastat installed during boiler set-up is "close-on-rise" type in operation. This control is set at 160 deg. F. and is connected to the circulator installed between the TARM 2000 boiler and the existing boiler. When the TARM 2000 is being fired and reaches operating temperature, this circulator will start and circulate water through both boilers. This allows the TARM 2000 to handle the domestic hot water and heating load on the other boiler. When the circulator in the piping to radiation is inactive, its resistance, plus that of the flow-check valve, will prevent circulation through radiation by the circulator between two boilers.

When the TARM 2000 is inactive, the flow-check valve installed between the TARM 2000 return and the oil- or gas-fired boiler supply prevents thermal siphoning and consequent standby loss from the TARM 2000. The aquastat on the existing boiler should be set as follows:

High Limit	165 deg. F.
Low Limit	145 deg. F.

The high limit setting of 165 deg. F. prevents the oil or gas burner from starting on a call for heat unless the TARM 2000 is unable to maintain this temperature. The low limit setting is the temperature at which the burner turns off when there is no call for heat. These settings can be raised if the TARM 2000 is not to be fired for an extended period of time. For further information on adjusting the aquastat of your oil- or gas-fired boiler, consult your distributor.

IV. ELECTRICAL WIRING

NOTE: All wiring must be completed as per the wiring diagram on this page. ALL WIRING MUST BE INSTALLED IN ACCORDANCE WITH NFPA STANDARD #70 AND THE NATIONAL ELECTRICAL CODE.

NOTE: The electrical system of the boiler shall be supplied from a single branch circuit except when the electrical sequencer kit has been installed in the TARM 2000 boiler. The boiler itself must be grounded in accordance with the requirements of the authority with jurisdiction, or, in absence of such authority, in accordance with the National Code, ANSI/NFPA #70-1978.

**SERIES HOOKUP**

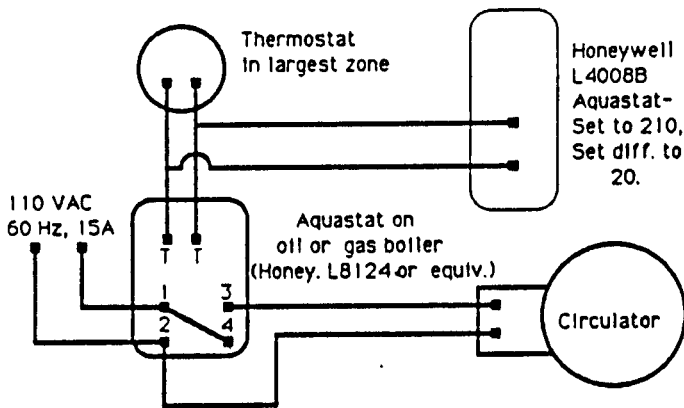

**ONLY BOILER**

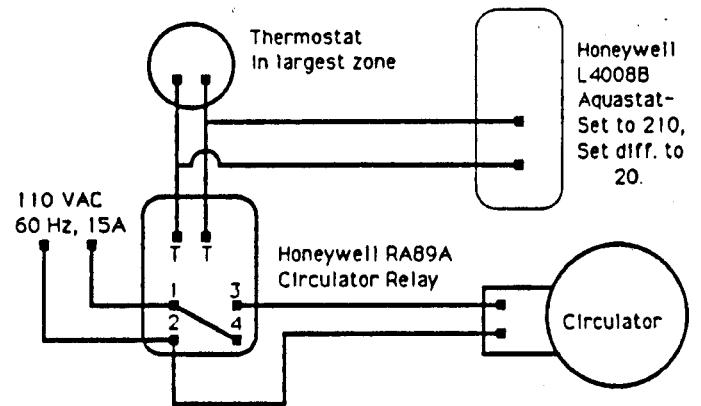

**PARALLEL HOOKUP**

1) OVERHEAT CONTROL

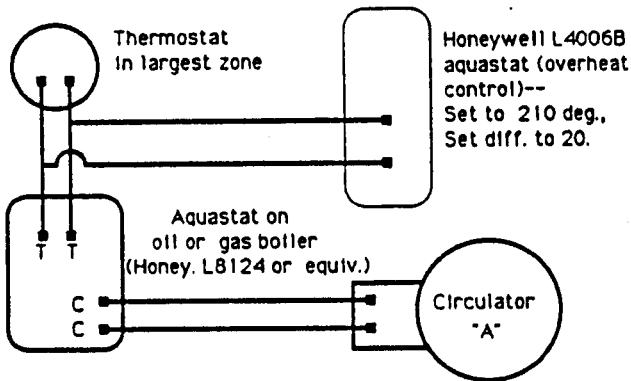

2) CIRCULATOR BETWEEN BOILERS

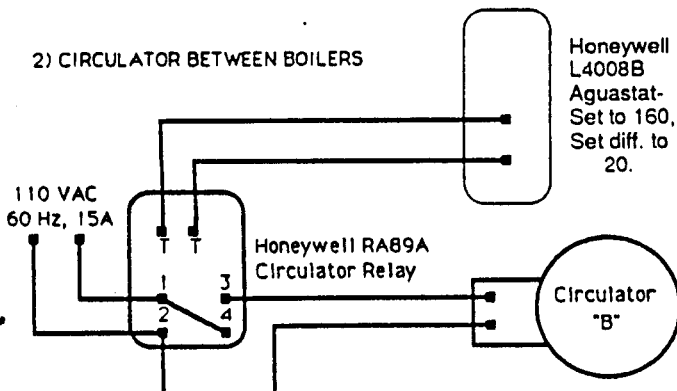

**AUTO-MIX SYSTEM**

1) OVERHEAT CONTROL

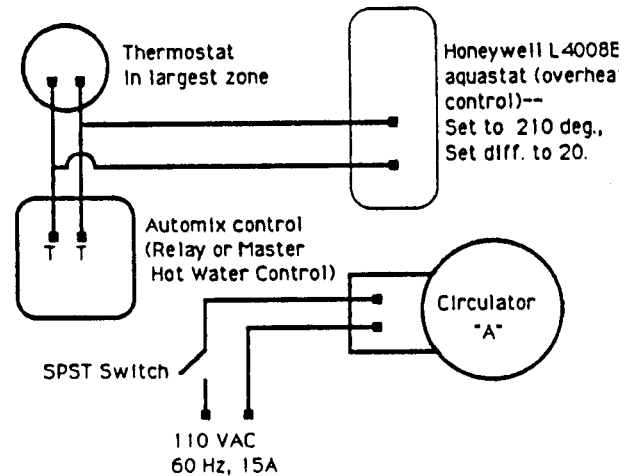

2) OPTIONAL CIRCULATOR

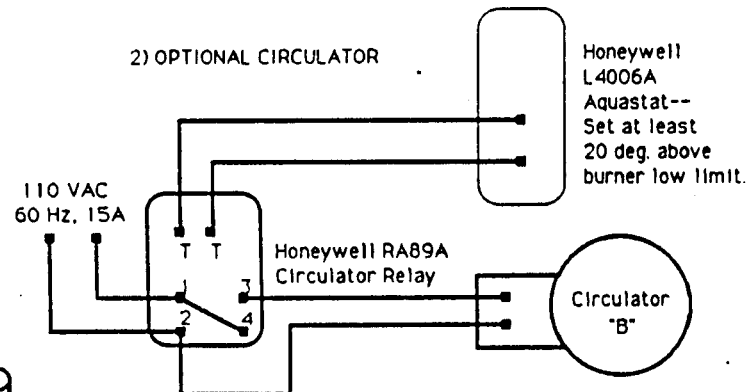

# WIRING DIAGRAM - TARM 2004

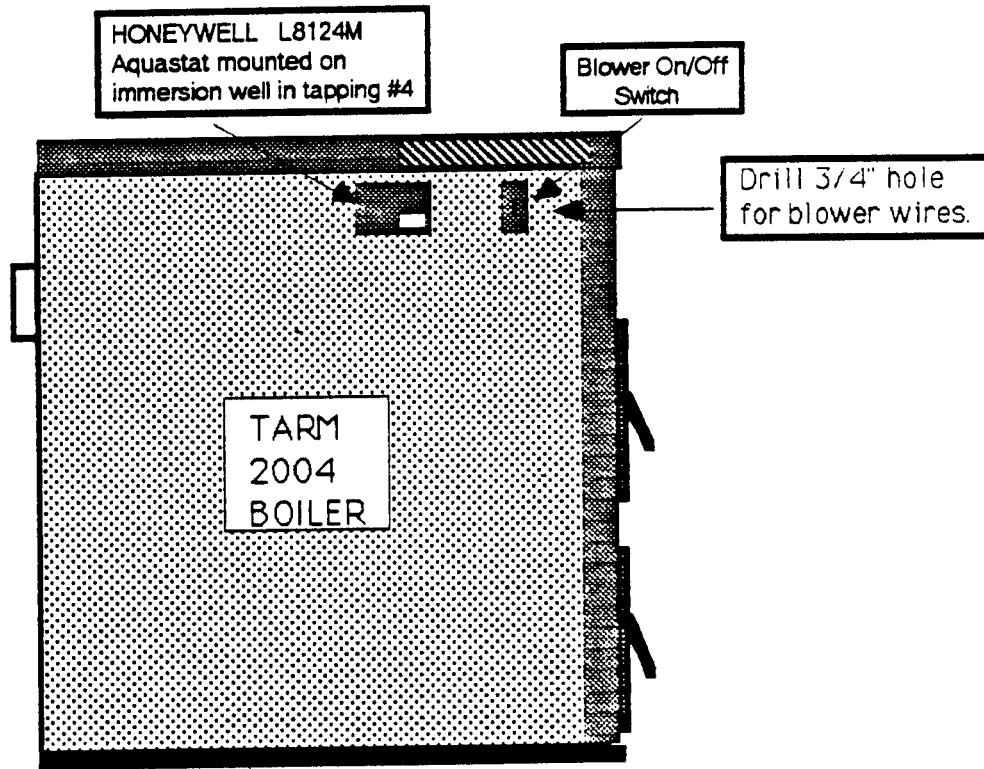

## SEQUENCE OF OPERATION

Low limit on Aquastat controls the Blower and setting is average operation temperature of boiler. High Limit setting is a safety shut-off for 110 volt Blower.

## SETTINGS ON L8124M

HIGH LIMIT	210°F
LOW LIMIT	180°F
DIFFERENTIAL	10°F

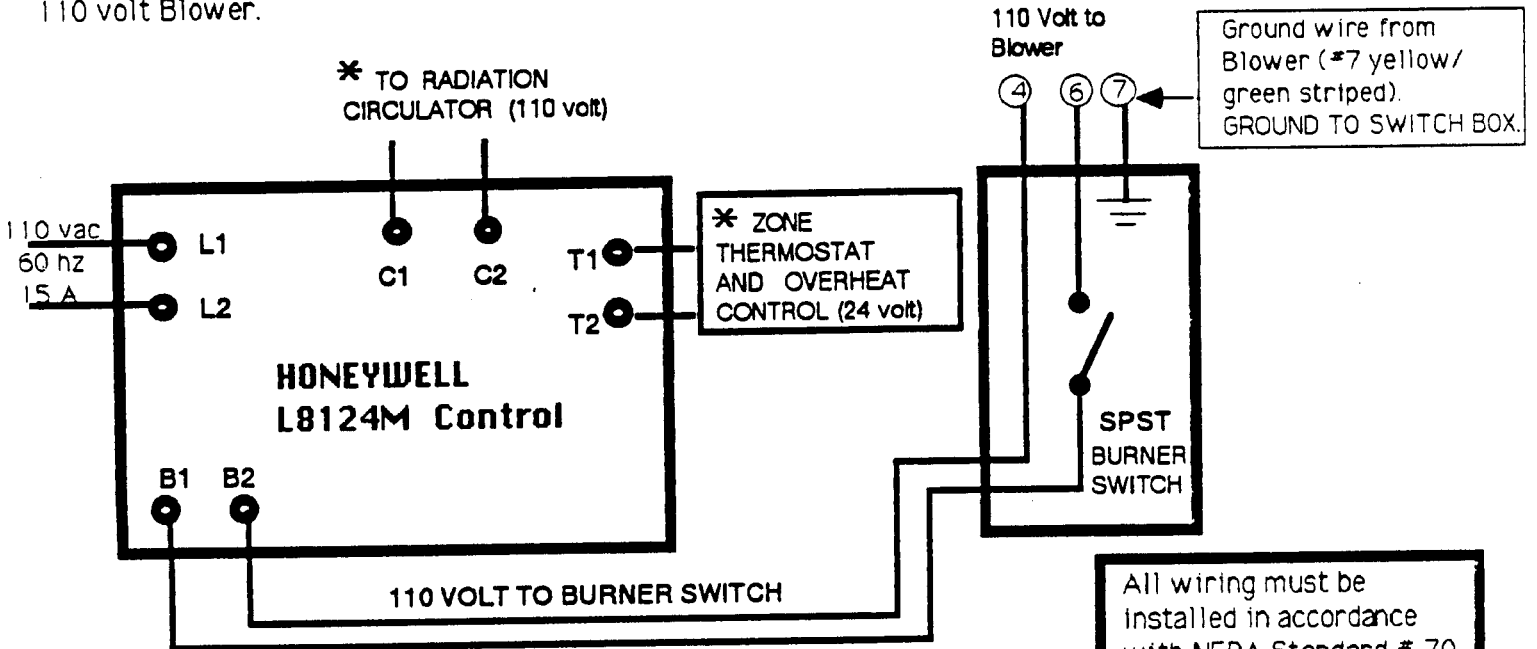

\* Make these connections only when there is no other boiler in the system.

All wiring must be installed in accordance with NFPA Standard # 70 and the National Electrical Code.

Very small pieces of Wood or wood pellets are not suitable fuels. COAL CANNOT BE USED IN YOUR TARM 2000 BOILER because there is no way to clear ash from the coal fire. Coal will also damage the refractory in the firebox.

### C. STARTING UP YOUR TARM 2000 BOILER

Before starting up your boiler for the first time, you must check that it has been properly filled with water and vented of air. It is important that the installer first check the thermostat control on the control panel (2002 only) and the overheat control Honeywell L4008B (located on the right side of the boiler) to ensure they are operating properly.

If possible, it is recommended that you bring the TARM 2000 boiler up to a temperature of 140 degrees F. with your back-up boiler or electric elements before you start a solid-fuel fire.

- 1) Set the by-pass flap in the open position by pulling the knob up and fully forward.
- 2) Open the loading door just an inch or two, then pause for a few seconds before opening fully. This will prevent any risk of burns should there be a small Wood-gas explosion when the door is opened.

NOTE: ALWAYS OPEN THE LOADING DOOR CAUTIOUSLY

- 3) To light the fire, first turn on the blower switch on the control panel (labeled BURNER on 2002) (mounted on side jacket on 2004) set the pointer on the temperature dial to approx. 12 o'clock (2002 only), and listen to see that the fan is running.
- 4) Line the bottom of the firebox with several sheets of crumpled newspaper, and lay several pieces of kindling on top. NOTE: Wood should always be loaded so that they lie straight from front to back never crooked - and are packed together as closely as possible.
- 5) Place 2 or 3 more sheets of crumpled newspaper on top of the kindling, light the paper and close the door.
- 6) Now close the bypass, pushing all the way in and down to lock in place.
- 7) After 2-3 minutes, carefully open the upper door and check to see that the fire is established. Small pieces of firewood can now be added.
- 8) Wait approximately 5 more minutes, then look through the sight-glass in the ash door. You should see a full purple flame filling the combustion tunnel. If not, give the fire a few more minutes before loading larger fuel.

NEVER USE GASOLINE, KEROSENE OR OTHER FLAMMABLE LIQUIDS TO START OR MAINTAIN SOLID-FUEL FIRES IN YOUR BOILER --SERIOUS BURNS OR PROPERTY DAMAGE MAY RESULT !

CAUTION: Firing and Ash doors must remain closed except when loading fuel or removing ash. Door gasket seals are very important to the operation of your boiler. They must be maintained in good condition and replaced if necessary in order to maintain an air tight seal. Replacement gaskets are available from your TARM distributor.

NOTE: Do not be alarmed if you smell an unusual odor the first few times you fire. This smell is due to burning of oil residues in the paint.

## E. ADJUSTING THE PRIMARY AIR

The primary air should be adjusted only if the draft in the chimney is too low for a good flame to form in the combustion tunnel (increase primary air), or if the flame is too large and cannot be confined to the tunnel (decrease primary air).

To adjust the primary air: Lift the front top jacket panel and move it to the rear (it will sit nicely on the rear top panel). Be careful not to pull the control panel sensors out of the well. Loosen the black plastic knob on the adjustment bolt (located on the blower mount), and thread the bolt in (less air), or out (more air). Check the flame and change the adjustment as necessary. Tighten the locking knob and remount the top front panel.

## F. STOKING THE FIRE

When restoking the fire, proceed as follows:

1. Open the by-pass flap by pulling the by-pass lever out.
2. Open the loading door approx. 1 inch with your left hand.
3. Wait approx 5 seconds.
4. Open the loading door completely.
5. Stack logs horizontally in the firebox - neatly, and not in a crisscross fashion.
6. Close the loading door
7. Close and lock the by-pass door by pushing in the lever.

## G. USE OF THE BYPASS

The bypass should always be opened before opening the loading door. This will minimize smoking and puff-backs. The bypass should always be locked tightly in the closed position when the boiler is in operation. During extended power failures (when the blower will not operate) you can produce some heat for your home by operating the boiler with the bypass open. See Section VII,B. "Procedure in the Event of a Power Failure".

## H. COMBUSTION

The TARM 2000 has excellent combustion characteristics, and pollution of the boiler (except for the firebox), chimney, and environment is kept to an absolute minimum.

NOTE: Your boiler firebox will form creosote because of the cold steel walls. This creosote has no effect on boiler operation, and does not need to be removed. When the fan is operating, the TARM 2000 burns at around 80% combustion efficiency producing very little exhaust smoke and ash. The fan shuts down during the off cycle. The fire in the firebox shuts down due to lack of oxygen. When the fan turns back on, the coals and heat of the firebrick re-ignite the fire for clean combustion.

## I. OUTPUT

The TARM 2000 is designed to operate in an output range from as low as 17,000 Btu's per hour to a maximum of 102,450 Btu's per hour (140,000 on 2004). At maximum operation the fan will operate continuously. At the lower outputs it will cycle on and off such as an oil burner. How far you can lower the output is dependent on the chimney draft. The chimney draft must always be high enough to prevent negative draft in the primary air duct, in which case smoke will be emitted through the fan when the fan is off.

NOTE: You will have greater creosote formation in the firebox during operation at lower output.

### SHUT-DOWN

If you are not firing the TARM 2000 on wood for any extended time periods (such as the summertime), you must maintain the boiler temperature at 140 deg. F in order to prevent condensation and corrosion. If you cannot maintain boiler temperature then you must either have a contractor drain the boiler or protect the boiler by taking the following steps:

- 1) Clean the inside of the boiler using the scraper and wire brush.
- 2) Remove all ash deposits from the boiler completely with a vacuum cleaner.
- 3) Remove and clean the flue pipe connecting the boiler to the chimney.
- 4) Do not replace the flue pipe.
5. Stuff insulation into the flue outlet of the boiler to block off air passing through the boiler
- 6) Keep all doors and air dampers closed.

If you still notice condensation forming inside the boiler firebox, hang a 15-25 watt light bulb inside the firebox.

### CAUTION:

IF YOUR TARM 2000 BOILER IS EQUIPPED WITH A DOMESTIC HOT WATER COIL, BE SURE THAT COLD WATER DOES NOT PASS THROUGH THE COIL WHEN THE BOILER IS SHUT DOWN !

---

### CAUTION: RISK OF WOOD-GAS EXPLOSION !

Please follow loading and starting directions as stated in the previous text. Be especially careful when opening the loading or ash doors while the boiler is operating. Under certain conditions, an unexpected back-flashing or puffing (wood-gas explosion) can occur when these doors are opened. This is caused by the sudden admission of air into the firebox (that had previously been air-starved). Any danger to the operator can be averted by using correct loading and tending procedures.

NOTE: The operators face should be always be kept well back until the door has been opened for a moment.

Please note the diagrams below to understand the cause of this phenomenon.

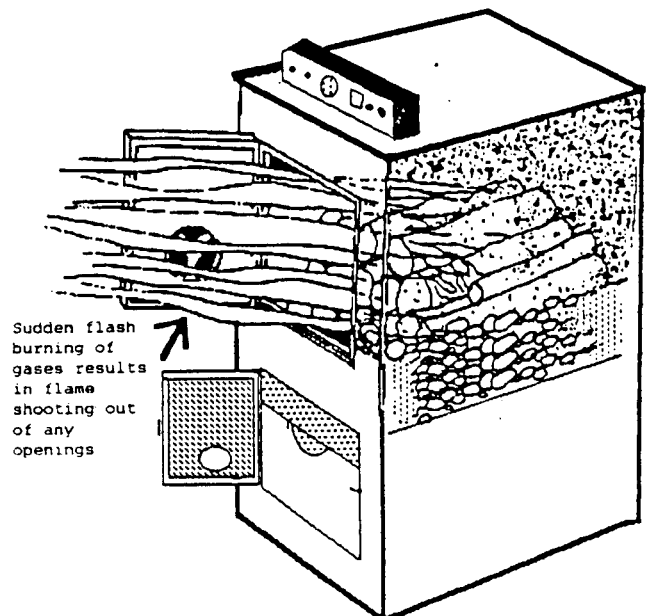
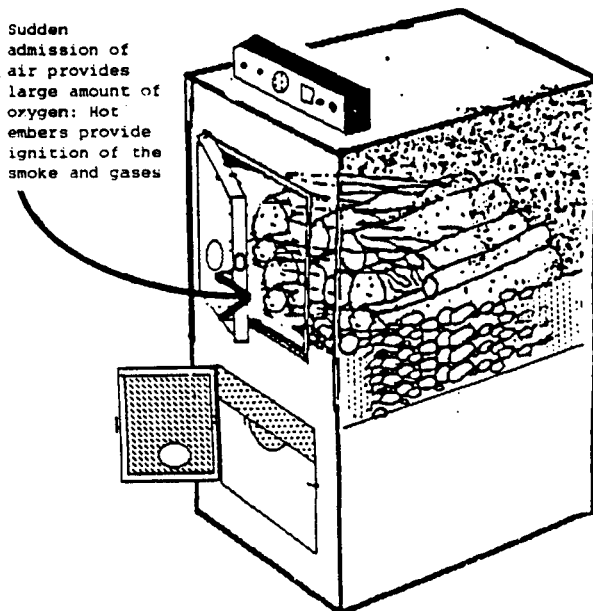

Following the recommendations in this manual will minimize the possibility of overheating, but even the most experienced person will occasionally overheat his boiler. To cope with this problem, the boiler is equipped with two safety devices-- the Overheat Control and the Pressure Relief Valve.

The overheat control is wired to circulate excess boiler heat to the house when the boiler reaches a preset temperature of 210 deg F. This control turns on the circulator and opens either the mixing valve or any zone valves in the largest heating zone. Generally, the overheated boiler can be cooled within 10 minutes.

If the overheating condition is more severe, the temperature will continue to rise. At about 250 deg .F., the pressure in the boiler will have reached 30 psi; and the pressure relief valve will open, discharging steam. For your information; all TARM 2000 boilers are pressure-tested to 60 psi at the factory.

TO PREVENT THE POSSIBILITY OF SERIOUS BURNS OR PROPERTY DAMAGE FROM THIS STEAM, THE DISCHARGE TUBE MUST BE PIPED TO A POINT 6" FROM THE FLOOR , OR TO A DRAIN !

The reason that steam rather than water is discharged is due to the fact that water under pressure can reach temperatures above 212 deg.F. without boiling (as in a boiler), but, when released to the atmosphere by the relief valve, water turns immediately to steam if it is over 212 deg. F.

TO COOL A SEVERELY OVERHEATED BOILER (relief valve discharging, or temperature rising over 230 deg F.) follow these steps:

- 1) Be sure the loading door and ash door are tightly closed.
- 2) Turn off the draft blower.
- 3) Be sure the by-pass is in the closed position.
- 4) Open all hot water faucets in the house if the boiler has a domestic hot water coil.
- 5) Turn all thermostats up to their highest setting.
- 6) Open windows as necessary to keep the house cool.

When the boiler has cooled to normal operating temperature, resume normal operation.

#### B. Procedure in Event of Power Failure

Should your electricity go off during the heating season, there are several procedures that should be followed in order that you may continue to safely operate your heating system. 1) Locate any "Flo-check" valves in the system, and unscrew completely the knob on top of each valve. (This will allow a certain amount of heated water to circulate by convection throughout the house, preventing the pipes from freezing and keeping the house partially heated.) If you have a mixing valve, open it to the highest setting, then lock it into position.

**SYMPTOM**

**CAUSE**

**SOLUTION**

Boiler functions well with good burn times but inadequate on coldest days

Boiler Temperature is set too low

Increase boiler water temperature by adjusting the FAN thermostat control for 200 deg water temperature.

Excessive heat dumped in overheat zone

Overheat control set too low.  
Blower thermostat set too high.

Set Honeywell L4008B at 210 to 230 deg F.

Short burn times

Wood not seasoned

Season wood for at least 8 months under cover

Firebox is not filled adequately

Cut wood to full length of firebox

Boiler undersized for home

Supplement heat with your oil or gas boiler

Wood fire goes out before being burned completely.

Inadequate draft

Increase chimney draft

No demand on boiler for an extended period of time

Burn back-up fuels or turn blower thermostat lower so that fan cycles on more often.

**AUTO-MIX SYSTEMS**

Does not maintain house at set temperature

Locking quadrant set too low for weather conditions

Reset locking quadrant on the mixing valve further to the right

**AUTO-MIX SYSTEMS**

House temperature is above thermostat setting

Locking quadrant set too far to the right

Reset Locking quadrant on the mixing valve further to the left.