

Lambdatronic Operating Instructions

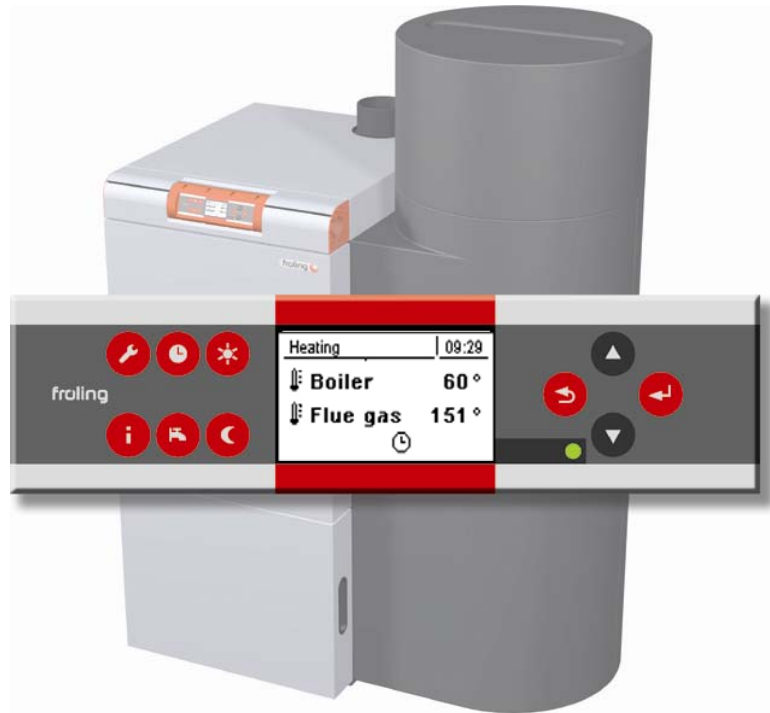

Lambdatronic P 3200 for Fröling Pellet Boiler P4 Pellet (from Version 50.04 - Build 04.11)

Tested &
Listed By  Portland
Oregon USA
OMNI-Test Laboratories, Inc.

TUV
AUSTRIA

1 General	5
1.1 About this introduction	5
1.2 Safety Information	5
1.3 Before switching on for the first time	6
1.3.1 Lambdatronic Check	6
1.3.2 Check the connected units	6
1.3.3 System Check	6
2 Overview of the Basic Functions	7
2.1 Control Keys and Display	7
2.1.1 Navigation Keys	7
2.1.2 Status LED	7
2.1.3 Function Keys.....	8
<i>Info Key</i>	9
2.1.4 Graphic display.....	10
2.2 Operating statuses	11
3 Operation	12
3.1 Initial startup	12
3.1.1 Changing the Operating Level.....	12
3.1.2 Setting the System Type	13
1. <i>Boiler Type</i>	13
2. <i>System selection</i>	14
3. <i>Hydraulic System</i>	14
3.1.3 Before heating up for the first time	14
<i>Drives</i>	14
<i>Check sensors</i>	15
<i>Setting sensor "Level Max"</i>	15
3.2 Starting the system	16
3.2.1 Feeding fuel into the combustion chamber	16
3.2.2 Start boiler	16
<i>Automatic mode</i>	16
<i>Modes in automatic mode</i>	16
<i>Summer mode</i>	17
3.3 Setting parameters	17
3.4 Setting times	18
Clearing the time window:	18
4 Menu Overview and Parameters	19
4.1 Menu - Heating	20
4.1.1 Status Displays for the Heating Circuits	20
4.1.2 Temperature settings for the heating circuits	20
4.1.3 Heating times of the heating circuits	21
4.1.4 Service parameters for heating circuit.....	21
4.2 Menu - Water	22
4.2.1 Status Displays for the DHW Tank.....	22

4.2.2 Temperature settings of the DHW tank.....	22
4.2.3 Heating times of the DHW tank.....	23
4.2.4 Service parameters of the DHW tank.....	23
4.3 Menu - Solar	24
4.3.1 Status displays for the solar system.....	24
4.3.2 Temperature settings for the solar system.....	24
4.3.3 Service parameters for Solar System	25
4.4 Menu - Storage tank	26
4.4.1 Status display of the storage tank.....	26
4.4.2 Temperature settings for storage tanks	26
4.4.3 Heating times of the storage tank	26
4.4.4 Service Parameters for Storage Tank.....	27
4.5 Menu - Boiler	28
4.5.1 Status Displays for the Boiler	28
4.5.2 Temperature Settings for the Boiler	28
4.5.3 Service parameters of the boiler	29
4.6 Menu - Boiler 2	30
4.6.1 Status Displays for the Secondary Boiler.....	30
4.6.2 Temperature Settings for the Secondary Boiler.....	30
4.6.3 Service Parameters for Secondary Boiler.....	31
4.7 Menu - Pellets	31
4.7.1 Fuel Filling Times.....	31
4.7.2 Service Parameters for Fuel Feed	31
4.8 Menu - Network pump	32
4.8.1 Network Pump Status Displays.....	32
4.8.2 Network pump temperature settings	32
4.8.3 Service parameters for the network pump	33
4.9 Menu - Difference regulator (Differential temperature regulating output)	34
4.9.1 Status displays for the difference regulator.....	34
4.9.2 Temperature settings for the difference regulator.....	34
4.9.3 Service Parameters for the Difference Regulator	35
4.10 Menu - Circulation pump	36
4.10.1 Status displays for the circulation pump.....	36
4.10.2 Temperature settings for the circulation pump.....	36
4.10.3 Time setting for the circulation pump	37
4.10.4 Service parameters of the circulation pump.....	37
4.11 Menu - Manual	38
4.11.1 Manual operation	38
4.11.2 Digital Outputs.....	38
4.11.3 Analogue Outputs	39
4.11.4 Digital Inputs	40
4.12 Menu - System	41
4.12.1 Adjustable parameters	41
<i>Adjustable Parameters - Boiler Temperature.....</i>	<i>41</i>

Adjustable Parameters - Flue Gas.....	41
Adjustable Parameters - Ignition.....	42
Adjustable Parameters - Air Settings.....	42
Adjustable Parameters - Pellet loading.....	43
Adjustable Parameters - Chamber Delivery Unit.....	43
Adjustable Parameters - Lambda Values.....	44
General Settings.....	44
4.12.2 Current system values.....	45
4.12.3 Error list.....	45
4.12.4 Parameters for sensors and pumps.....	46
4.12.5 Operating rights and allocations for displays.....	46
4.12.6 Basic display parameters.....	47
4.12.7 Set mode.....	47
4.12.8 Language Settings.....	47
4.12.9 Time settings.....	47
4.12.10 Standard settings.....	48
4.12.11 Current User Level.....	48
4.12.12 System parameters.....	48
4.13 Boiler Type-Related Factory Settings	48
5 Troubleshooting	49
5.1 Error display	49
6 Electrical Connection and Wiring	50
6.1 Core module	50
6.1.1 Connection instructions.....	50
6.1.2 Mains connection.....	51
6.1.3 Connecting the Flue Gas Sensor.....	51
6.1.4 Combination with Oil Burner.....	52
6.1.5 Connecting the remote control.....	52
6.1.6 Boiler release input.....	53
6.1.7 Error message switch.....	53
6.2 Expansion modules	54
6.2.1 Heating circuit module.....	54
<i>Connection instructions</i>	54
6.2.2 Hydraulic System Module.....	55
<i>Connection instructions</i>	55
6.2.3 Pellet module.....	56
<i>Connection instructions</i>	56
6.2.4 Pellet Module Expansion.....	57
<i>Connection instructions</i>	57
6.2.5 Connecting the bus cable.....	58
6.2.6 Setting the module address.....	58
6.2.7 Setting end jumper.....	59
6.3 Universal suction system	59
7 Setting protocol	60
8 Index Directory	62

Dear customer,

Please read and observe the operating instructions, particularly the safety information, and always keep them close by the boiler for reference.

1 General

1.1 About this introduction

These operating instructions include important information about operation, electrical connection and troubleshooting for the Lambdatronic P 3200. All parameters, which are visible at the customer operator level and service technician operator level, are shown.

The constant further development of our products means that there may be minor differences from the pictures and content. If you discover any errors, please let us know.
Subject to technical change.

1.2 Safety Information

CAUTION	
Do not touch hot surfaces and flue gas pipes!	
	Burns hazard!
Before carrying out work on/in the boiler:	
ρ Shut down the boiler in a controlled way with the service key and wait until it reaches the status "Burner OFF" and the boiler has cooled down	

CAUTION	
Working on electrical components.	
	Risk of injury from electric shock!
ρ Work on electrical components should be carried out by authorised professionals.	
ρ Observe all applicable standards and regulations!	
+ Work on electrical components by unauthorised personnel is absolutely forbidden!	

+ **The information on safety, standards and guidelines in the operating instructions for the boiler should also be observed.**

1.3 Before switching on for the first time

NOTICE

- + You should have the initial startup carried out by the authorised professional from Fröling customer services.

1.3.1 Lambdatronic Check

- ρ Check boards for foreign bodies (pieces of wire, washers, screws)
- ρ Carry out wiring check:
Check for loose, uninsulated wires, which could cause a short-circuit
- ρ Check plug arrangement of pumps, mixers and other units, which have NOT been prepared by Fröling
- ρ Check the connection of the BUS cable for short-circuits
- ρ Check the specified addresses and terminal jumper on the individual modules (heating circuit modules, hydraulic modules, displays,...)

1.3.2 Check the connected units

- ρ Check that all units that are used are connected correctly
- ρ Carry out wiring check:
Check for loose or uninsulated wires in the terminal boxes of the pumps, mixers and switch valve, which could cause a short-circuit

1.3.3 System Check

- ρ Check that the main fuse for the boiler has a sufficient rated amperage (16A)
 - + If a safety overload switch is used, it should be a type with 16A and "Tripping Characteristic C".



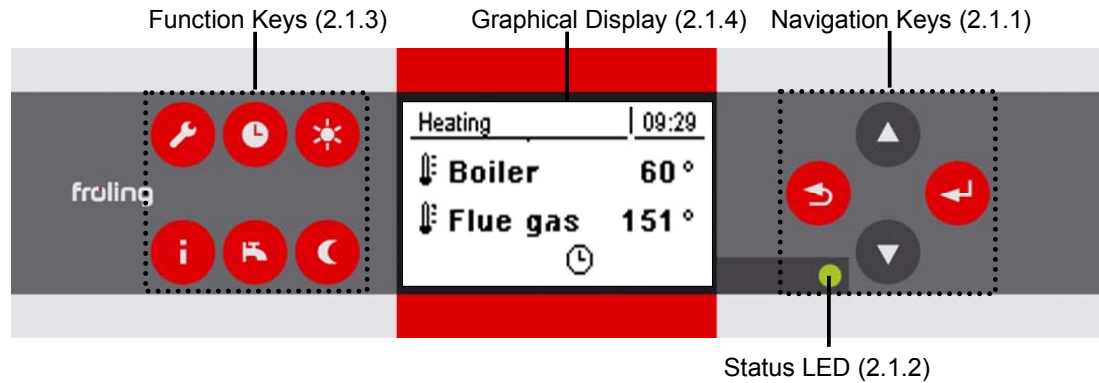

2 Overview of the Basic Functions

2.1 Control Keys and Display



2.1.1 Navigation Keys

The navigation keys are for moving around the menu and changing parameter values.

Key	Function with
 UP arrow	Navigation: Move up in the menu
	Parameter change: <ul style="list-style-type: none"> Short keystroke: Increase value Long keystroke: Increase value in steps of 10 Long keystroke (> 10 sec): Increase value in steps of 100
 DOWN arrow	Navigation: Move down in the menu
	Parameter change: <ul style="list-style-type: none"> Short keystroke: Decrease value Long keystroke: Decrease value in steps of 10 Long keystroke (> 10 sec): Decrease value in steps of 100
 Enter key	Navigation: Go to selected menu
	Parameter change: <ul style="list-style-type: none"> Short keystroke: Unlock parameter for editing or save parameter value
 Back key	Navigation: Go back to higher menu
	Parameter change: <ul style="list-style-type: none"> Short keystroke: Do not save parameter value Long keystroke: Back to basic display without saving

2.1.2 Status LED

The status LED shows the operating status of the system:

















- green flashing light: **BOILER ACTIVE**
- flashing red light: **WARNING** or **FAULT**

2.1.3 Function Keys

The function keys of the Lambdatronic P 3200 have dual functions. Different functions can be called with long or short keystrokes, using the following definitions of keystroke duration:

Short keystroke < 1 sec

Long keystroke > 4 sec

Keystroke		Function / Symbol in status line		
 Service Program	Short	Chimney-sweep mode	System is operated for 30 mins with rated load	
	Long	Service mode	Control follows the boiler shutdown procedure and after the cleaning cycle the grate stays in open position. The ID fan runs at controlled speed and the door contact switch is activated. + Recommended for ash discharge	
 Automatic program	Short	Automatic mode (mode)	Heating circuits and domestic hot water are controlled according to the programs and times set.	
	Long	Off	The control follows the boiler shutdown procedure and starts with the cleaning cycle. After the cleaning cycle the boiler goes to "Burner Off" status. The Lambdatronic controls the connected heating components. All parts of the boiler are deactivated.	
 Party program	Short	Party mode	Only with room console! After an optional change to the room temperature set value the control of the heating circuits stays in heating mode until the end of the next heating time or until activation of the automatic mode. Function not possible in summer mode!	
	Long	Extra heating	Heating and domestic hot water are heated for 6 hours The mode set is ignored. + Caution: External temperature heating limit active!	
 Info	Short	Display info text	Query / Clear text information on menu points or errors.	
	Long	No function	Page 9, "Info Key"	
 DHW tank program	Short	Extra loading	Manual loading of domestic hot water.	
	Long	Summer mode	Domestic hot water loading according to specified program, heating circuits are deactivated. + Caution: No frost protection!	
 Setback program	Short	Setback mode	Only with room console! After an optional change to the setback temperature the control of the heating circuits remains in setback mode until the start of the next heating time or until activation of another mode.	
	Long	Continuous setback	Only with room console! The room temperature is reduced to the preset setback temperature until automatic mode is activated.	

Info Key



The info key can be pressed at any time and always shows information about the current menu item or the current fault message, with fault messages occupying the highest priority.

Info key in normal mode:

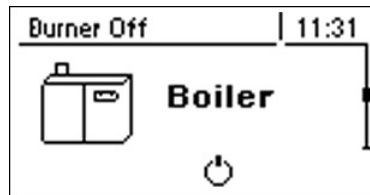

In normal mode (without faults) the info key can be pressed to display information or an explanation for every menu point or parameter.

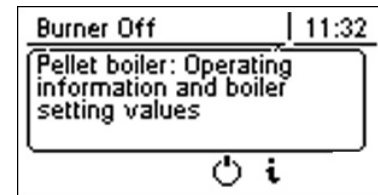

The info text is also identified by the frame and the info symbol in the symbol tab.

Info key for pending warning or fault:

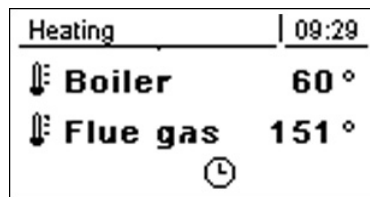

If a fault was acknowledged after arising, but not resolved, this is displayed by a warning symbol at the bottom right on the symbol tab.

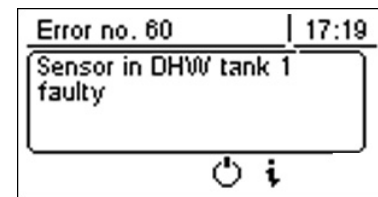

Pressing the info key calls up the information on the currently pending fault message again.
Procedure for troubleshooting:

└ Page 49, Troubleshooting

2.1.4 Graphic display

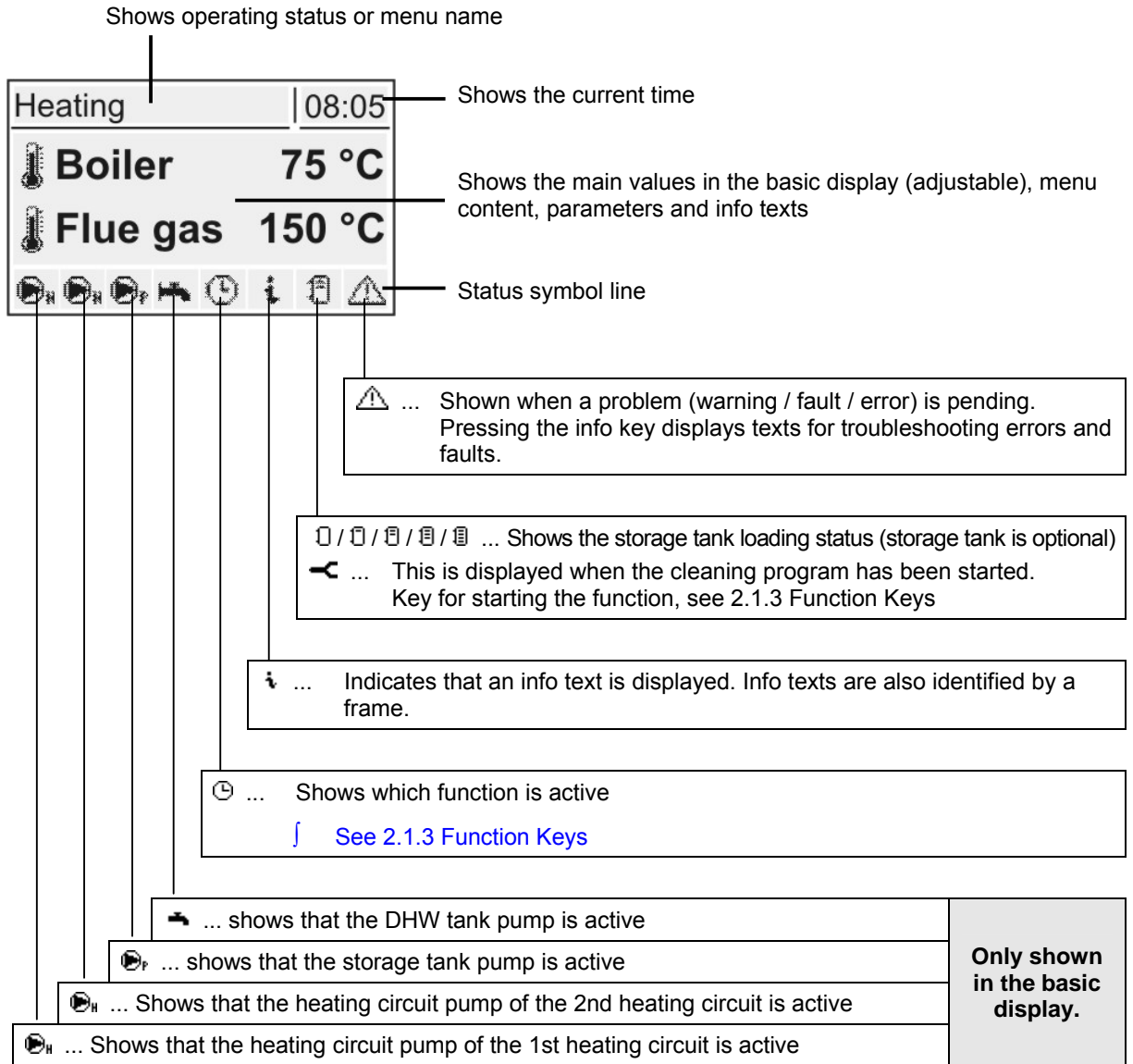

At the service technician operating level the function of the relevant components is signalled in the individual status menus through the corresponding status display:

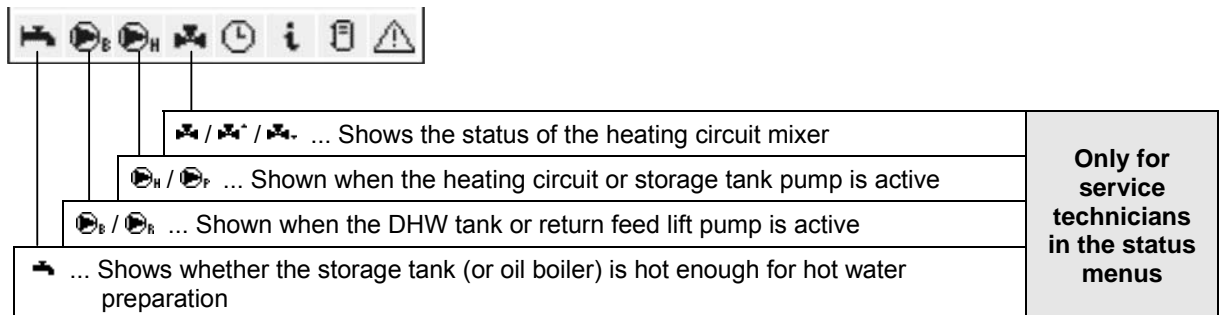

2.2 Operating statuses

There are 12 different boiler statuses, which are shown at the top left of the graphic display:

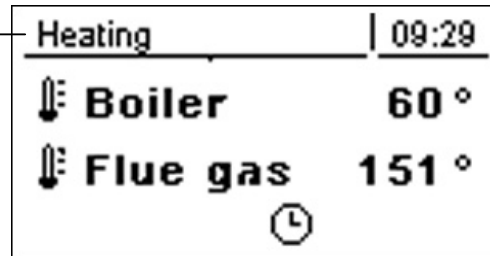

Preparation	The boiler is ventilated, the sealing slider is opened and the Lambda probe is heated.
Heating up	The combustion chamber is filled with pellets.
Pre-heating	The fan-assisted ignition switches on and the pellets are preheated until a bed of embers is formed. For this period loading is deactivated.
Ignition	The pellets are ignited with the fan-assisted ignition. The flame is distributed around the whole combustion chamber. The control of the loading unit is defined as "Ignition" in the parameter menu.
Heating	The Lambdatronic controls combustion according to the boiler setpoints.
Constant burn	The boiler has no power consumption. The ID fan and the loading unit are deactivated.
Cleaning	The Lambdatronic carries out the cleaning program (duration approx. 3 min). The grate and heat exchanger are cleaned.
Shutdown wait	When the boiler is interrupted during the heating up procedures (heating up, pre-heating, ignition), it waits for a specified period of time until the next start attempt.
Shutdown wait 1	The ID fan runs to burn the remaining pellets. The loading unit is deactivated.
Shutdown wait 2	The system is still ventilated by chimney draught. The loading unit is deactivated.
Fault	CAUTION - Fault persists!] Procedure see page Chapter 5 - Troubleshooting
Burner Off	The Lambdatronic controls the connected heating components. All parts of the boiler are deactivated.

3 Operation

- + Before the initial startup check the wiring of the pumps and mixers is correct.
└ See 1.3 Before switching on for the first time
- + Check that the connected components have maximum connected load.
└ See 6.1 Core module or 6.2 Expansion modules

3.1 Initial startup

After power up the start logo is displayed. The control performs the system check.

After the system check the basic display is shown.

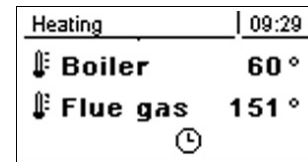

3.1.1 Changing the Operating Level

For safety reasons certain parameters are only visible at specific operating levels. To change to another level it is necessary to enter the relevant user code:

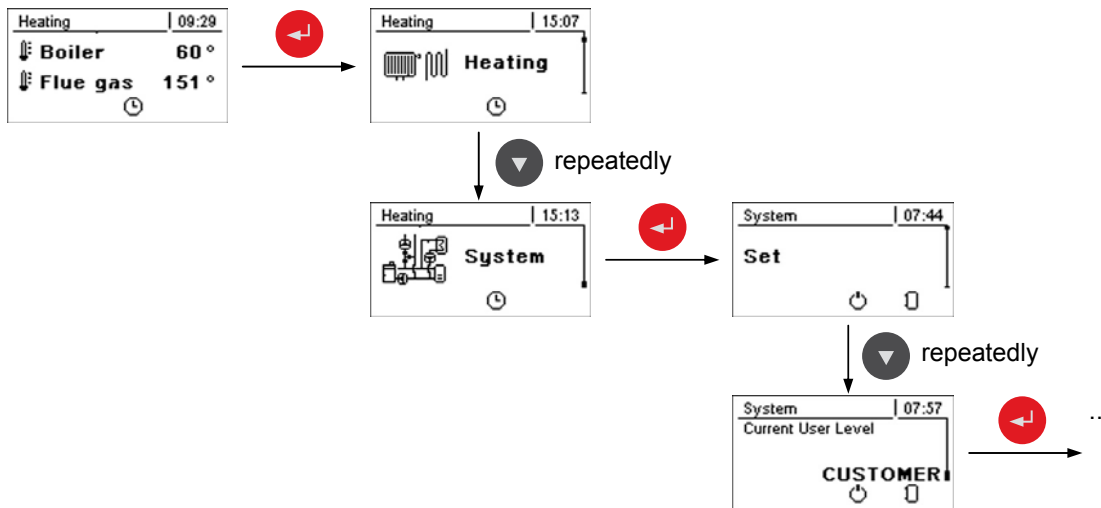

Child lock (Code 0)	At "Child lock" level, only the basic readout is displayed. It is not possible to change parameters at this level.
Customer (Code 1)	Standard level for normal operation of controls. All customer-specific parameters can be displayed and altered.
Installer / Service	Releases parameters to adjust controls to the system components. All the parameters shown in these operating instructions are available.

3.1.2 Setting the System Type

+ Only for trained personnel - the installer code must be entered!

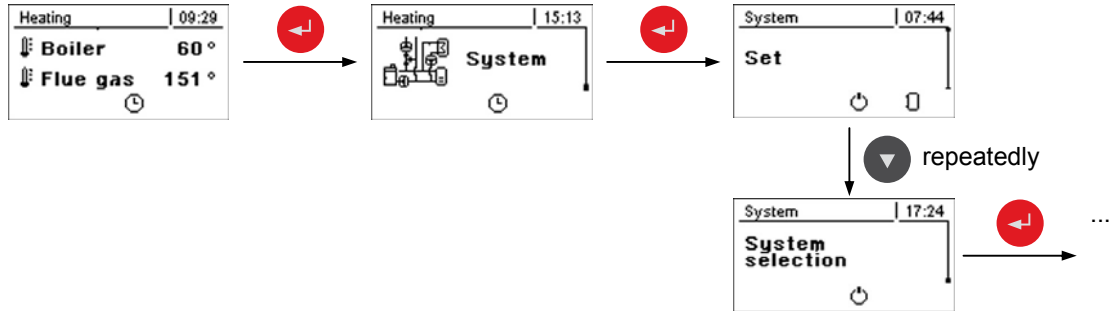

1. Boiler Type

... <input type="text" value="Boiler type"/>	-	S4 Turbo : FHG Turbo 3000 20 : Pellet boiler P2 - 10 :	-	DO NOT SELECT!
		P4 Pellet 8 - 25 SELECTED ←	-	P4 boiler type: P4 Pellet 8 P4 Pellet 15 P4 Pellet 20 P4 Pellet 25
		P4 Pellet 32 - 38 ←	-	P4 boiler type: P4 Pellet 32 P4 Pellet 38
		Turbomatic : Wood boiler F2 22/30	-	DO NOT DIAL!

Boiler type parameters:

... <input type="text" value="Lambda probe installed"/>	YES
<input type="text" value="Boiler release - input installed"/>	NO
<input type="text" value="Boiler stops automatically when no heat required"/>	NO
<input type="text" value="Supply bin installed"/>	NO
<input type="text" value="Vacuum screw filling system installed"/>	NO
<input type="text" value="Universal suction, manually operated"/>	YES
<input type="text" value="Universal suction, automatically operated"/>	NO

2. System selection

... System selection	<table border="1"> <tr> <td>Hydraulic System 0</td> <td>Selected</td> </tr> <tr> <td>Hydraulic system 1</td> <td></td> </tr> <tr> <td>Hydraulic system 2</td> <td></td> </tr> <tr> <td>Hydraulic system 3</td> <td></td> </tr> </table>	Hydraulic System 0	Selected	Hydraulic system 1		Hydraulic system 2		Hydraulic system 3		<table border="1"> <tr> <td>SELECT</td> </tr> <tr> <td>] For description see brochure "Lambdatronic P3200 Energy Systems" </td> </tr> </table>	SELECT] For description see brochure "Lambdatronic P3200 Energy Systems"
Hydraulic System 0	Selected											
Hydraulic system 1												
Hydraulic system 2												
Hydraulic system 3												
SELECT												
] For description see brochure "Lambdatronic P3200 Energy Systems"												
	Hydraulic system for F2 Boiler	DO NOT DIAL!										
	<table border="1"> <tr> <td>Hydraulic System 12</td> <td></td> </tr> <tr> <td>Hydraulic System 13</td> <td></td> </tr> </table>	Hydraulic System 12		Hydraulic System 13		<table border="1"> <tr> <td>SELECT</td> </tr> </table>	SELECT					
Hydraulic System 12												
Hydraulic System 13												
SELECT												
	<table border="1"> <tr> <td>H3200 Variant 1</td> <td></td> </tr> <tr> <td>H3200 Variants 2 and 5</td> <td></td> </tr> <tr> <td>H3200 Variant 3</td> <td></td> </tr> <tr> <td>H3200 Variant 4</td> <td></td> </tr> </table>	H3200 Variant 1		H3200 Variants 2 and 5		H3200 Variant 3		H3200 Variant 4		<table border="1"> <tr> <td>Multiple house schemes System Variants 1 to 5</td> </tr> </table>	Multiple house schemes System Variants 1 to 5	
H3200 Variant 1												
H3200 Variants 2 and 5												
H3200 Variant 3												
H3200 Variant 4												
Multiple house schemes System Variants 1 to 5												

3. Hydraulic System

... DHW tank system	<table border="1"> <tr> <td>DHW tank 01 installed</td> <td>Y/N</td> </tr> <tr> <td>:</td> <td></td> </tr> <tr> <td>DHW tank 08 installed</td> <td>Y/N</td> </tr> </table>	DHW tank 01 installed	Y/N	:		DHW tank 08 installed	Y/N				
DHW tank 01 installed	Y/N										
:											
DHW tank 08 installed	Y/N										
... Heating system	<table border="1"> <tr> <td>Heating circuit 01 installed</td> <td>Y/N</td> </tr> <tr> <td>Remote control 01 installed</td> <td>Y/N</td> </tr> <tr> <td>:</td> <td></td> </tr> <tr> <td>Heating circuit 18 installed</td> <td>Y/N</td> </tr> <tr> <td>Remote control 18 installed</td> <td>Y/N</td> </tr> </table>	Heating circuit 01 installed	Y/N	Remote control 01 installed	Y/N	:		Heating circuit 18 installed	Y/N	Remote control 18 installed	Y/N
Heating circuit 01 installed	Y/N										
Remote control 01 installed	Y/N										
:											
Heating circuit 18 installed	Y/N										
Remote control 18 installed	Y/N										
... Solar system	<table border="1"> <tr> <td>Solar collector 01 installed</td> <td>Y/N</td> </tr> </table>	Solar collector 01 installed	Y/N								
Solar collector 01 installed	Y/N										

3.1.3 Before heating up for the first time

- ρ Check the system pressure of the heating system
- ρ Check that the heating system is completely vented
- ρ Check if the safety devices are present and working correctly
- ρ Checking to see whether there sufficient ventilation and venting of the boiler room is guaranteed.
- ρ Check the seal of the boiler
 - + All doors and inspection openings must be tightly sealed!

Drives

- ρ Check that drives and servomotors are working and turning in the right direction
 -] [Page 32, Analogue outputs and digital outputs](#)

Check sensors

Check the sensor shown below in the digital input menu:

[Page 32, Digital inputs](#)

Sensor	Layout	Description
Door contact	A 0 ... Door closed, switch activated A 1 ... Door open, switch not activated	Set the switching point so that when an ash door is opened the ID fan runs.
Jam sensor	Jam sensor (N/O): A 0 ... Sensor not covered A 1 ... Sensor covered	The jam sensor is used for suction systems with screw delivery and is mounted at the suction piece. The setting is the same as sensor "Level Max".
Max level	Max level (opener): A 0 ... Sensor covered A 1 ... Sensor not covered	Setting sensor "Level Max"
Grate open	Grate closed ... A 0 Grate open ... A 1	The two parameters must always be different.
Grate closed	Grate closed ... A 1 Grate open ... A 0	

Setting sensor "Level Max"

In delivery configuration, the factory settings of the sensor are secured with a seal. Changes to the settings should only be carried out by qualified technicians.

- + The monitoring LED (1) should only light up when identifying materials!
- ρ If the monitoring LED stays on permanently, the sensitivity is set too high!
 - Σ Reduce the sensitivity by turning the adjusting screw (2) to the left
- ρ If the monitoring LED does not react when pellets are being fed in, the sensitivity is set too low!
 - Σ Increase the sensitivity of the adjusting screw by turning to the right

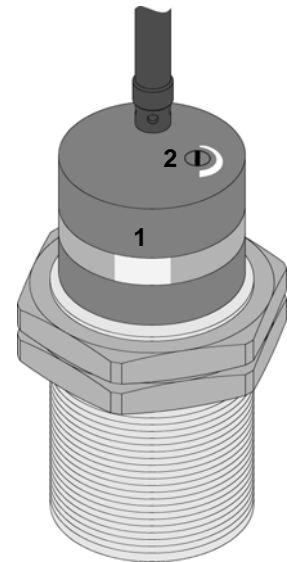

3.2 Starting the system

3.2.1 Feeding fuel into the combustion chamber

At initial startup there are no pellets in the stoker:

- ρ Set the parameter, “Manual filling of the pellet container” to **ON**
 - Σ The cyclone is filled with pellets, it switches off automatically at 100% fill level and sets the parameter back to **OFF**
- ρ Set the parameter “Manual Feed to Combustion Chamber” to **ON**
- ρ As soon as the first pellets fall into the combustion chamber set the parameter back to **OFF**
 - + Observe the process in the inspection window of the stoker screw
 - + If the parameter was reset too late and for this reason the grate is covered with pellets, this must be opened in manual operation so that the pellets can fall down, avoiding overfilling when the system starts and a possible flash fire.

3.2.2 Start boiler

Automatic mode

- ρ Press on the control 
 - Σ Heating circuits and domestic hot water are controlled according to the programs and times set.
 - Σ The clock symbol is shown in the status line of the graphic display.

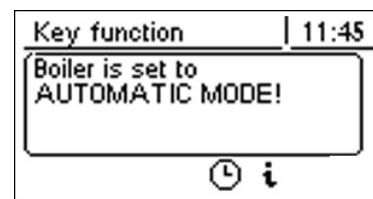

Modes in automatic mode

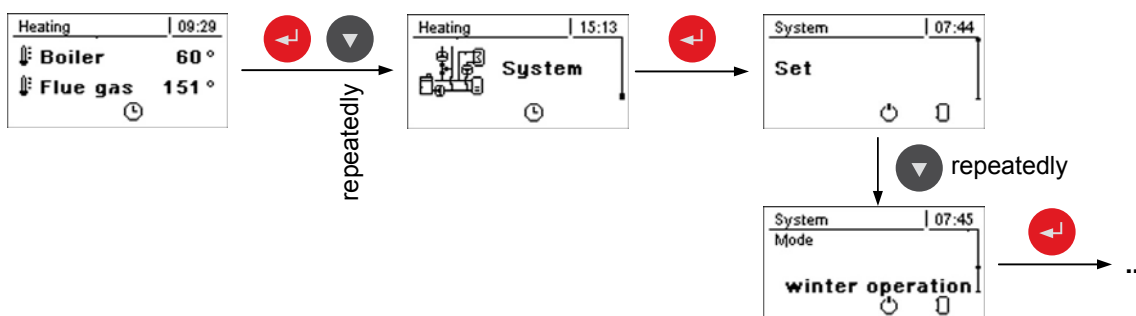

Winter mode	The Lambdatronic controls the heating and hot water heating according to the specified timed program. The boiler is constantly regulated to the temperature setpoint.
Transition mode without storage tank:	As with winter mode, heat is only produced in up to four adjustable time windows. At the end of the time window the boiler follows the shutdown procedure and goes “Burner Off” status.
Transition mode with storage tank:	The boiler only creates heat during the specified storage times (Storage tank management). Heating and hot water are active.
Summer mode	The domestic hot water is prepared in the boiler loading times set. All heating circuits switched off.

Summer mode

- ρ Press the  key on the controls and hold it for 5 seconds
 - Σ The boiler only controls the hot water heating according to the timed program settings.
 - Σ There is no frost protection for the heating circuits
 - Σ The tap symbol is shown in the status line of the graphic display.



For other modes press the relevant function key:

 [Page 8, 2.1.3 Function Keys](#)

3.3 Setting parameters

Values for all parameters are changed in the following way:

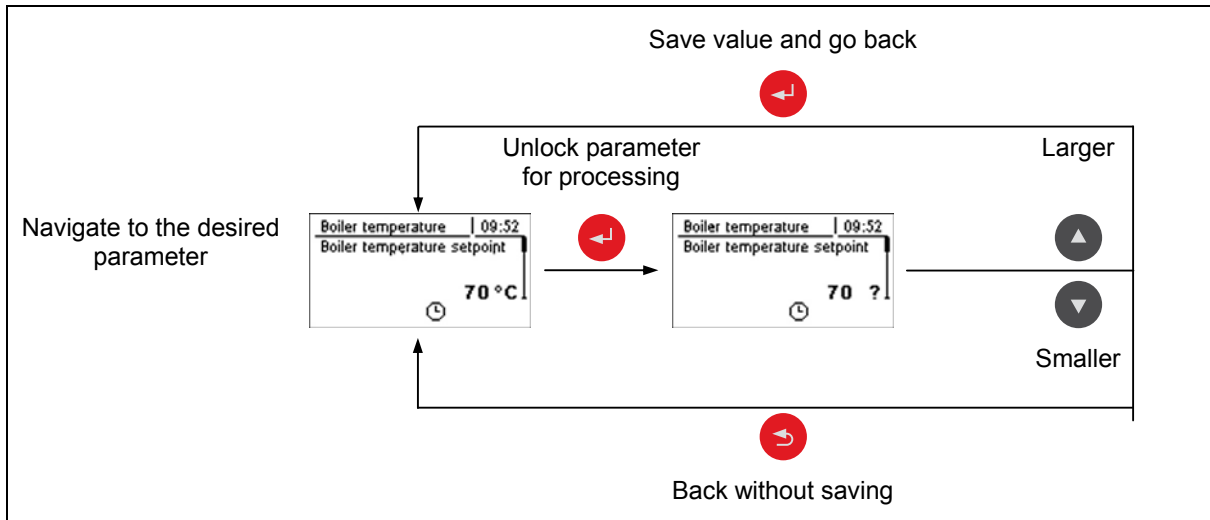

For initial startup the following parameters should be checked and adjusted if required:

- **Heating curve:** Radiator or underfloor heating
- + The other parameters are factory set in such a way that in most cases optimal operation is possible without making further changes to the parameters.

The following parameters, however, can/should be set as desired by the customer:

- **Desired boiler temperature setpoint**
- **DHW tank loading times**
- **Storage tank loading times**
- **Solar system control**
- **Heating and setback times of the individual heating circuits**
- **Start of automatic filling of pellet container**

3.4 Setting times

The "Times" menu can be called up in the individual menus of the heating components. The structure of the time menu and the procedure for changing the times is always the same!

Example - Setting times for heating circuit 01:

In "Heating" menu -> "Times":

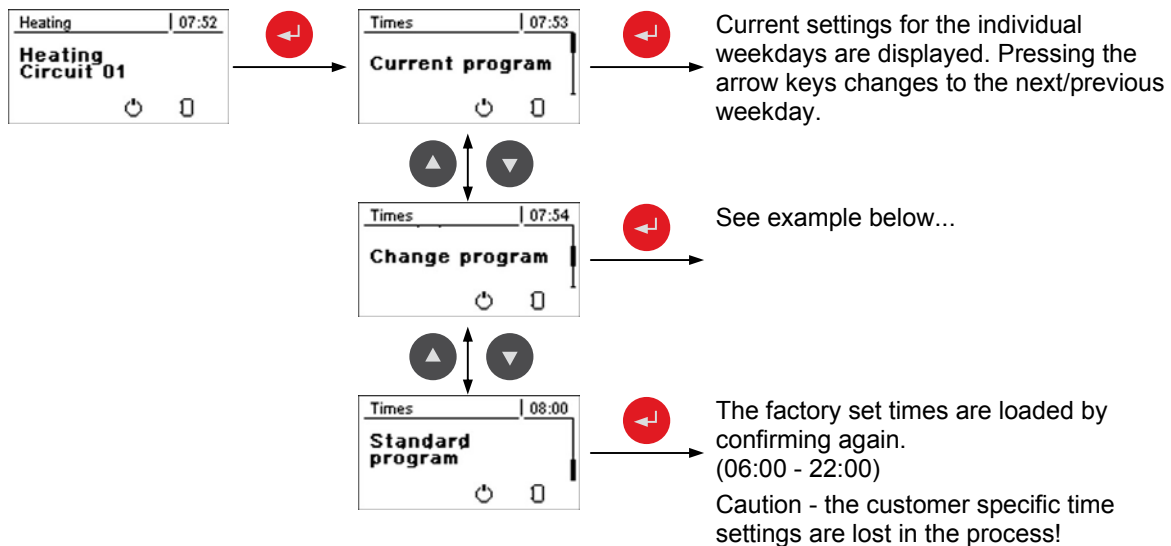

... in "Change program" menu:

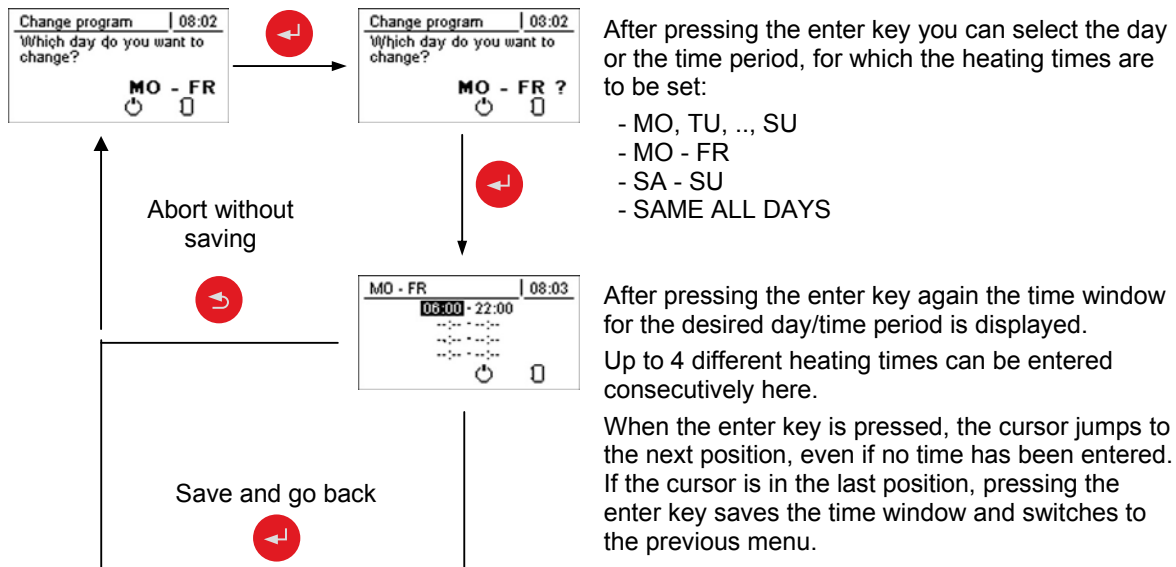

Clearing the time window:

Changed the end time of the desired time window to 24:00. If you press the up arrow key repeatedly the time disappears and is replaced by dashes. Then carry out the same process with the start time. Repeatedly pressing the enter key takes you back to the previous menu saving the times.

4 Menu Overview and Parameters

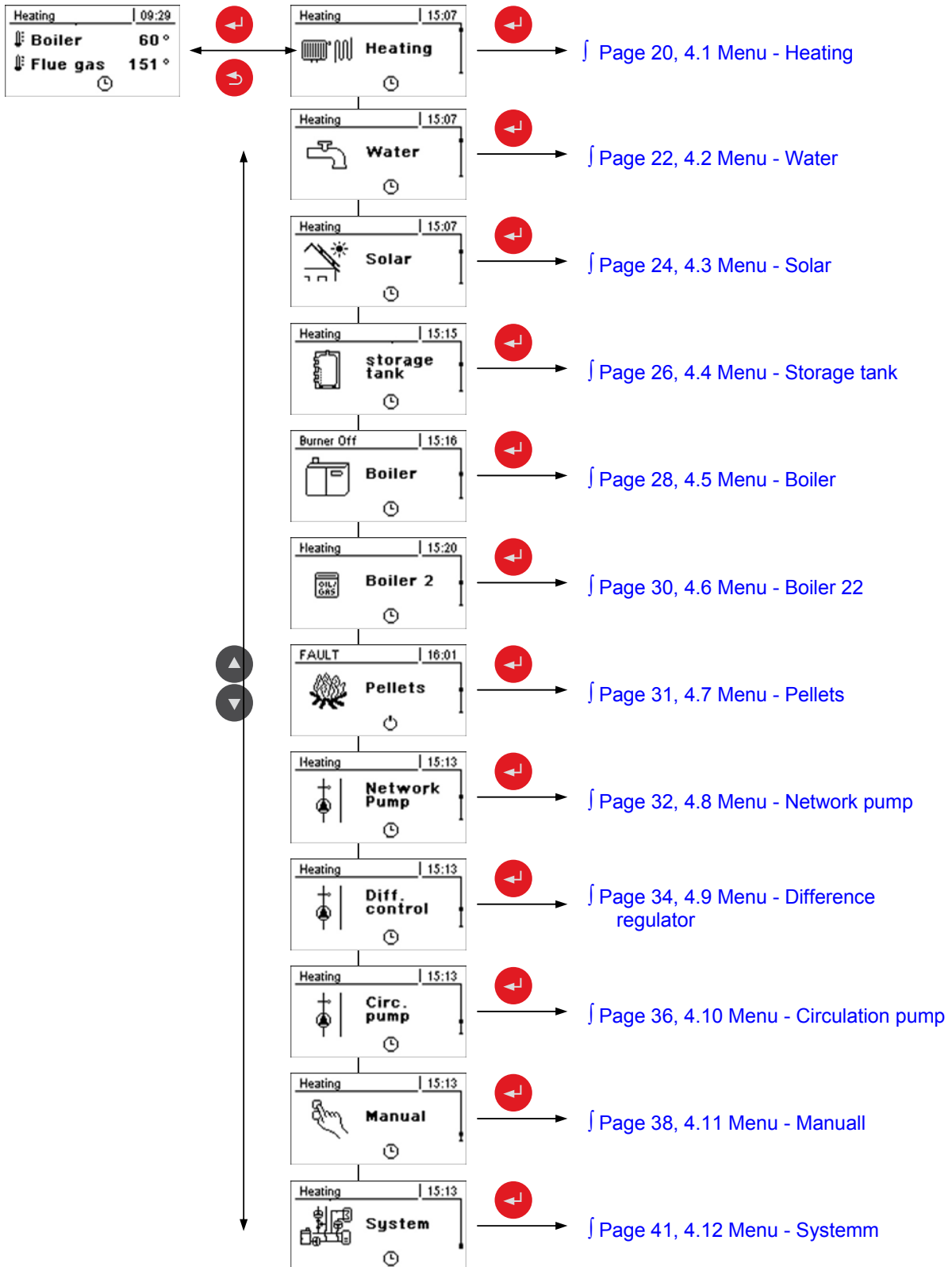

4.1 Menu - Heating

4.1.1 Status Displays for the Heating Circuits

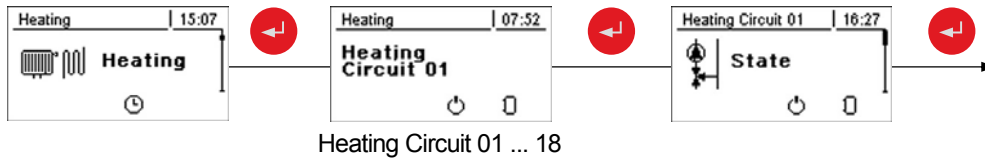

Display		Description
Control heating circuit according to prog.	YES	No → Heating circuit is completely switched off No frost protection!
Actual flow temperature	46°C	Shows the current flow temperature.
Flow temperature setpoint	52°C	The calculated flow temperature setpoint.
Room temperature	21°C	Temperature on remote control of the current heating circuit (option).
Override switch	Auto	Shows the current switch setting on the remote control (option) 1 = Party mode (*), the setback mode is ignored Setback = setback mode (C); heating mode is ignored Auto = Automatic mode (⌚); heating/ setback mode according to heating times
External temperature	2°C	Shows the current external temperature.

4.1.2 Temperature settings for the heating circuits

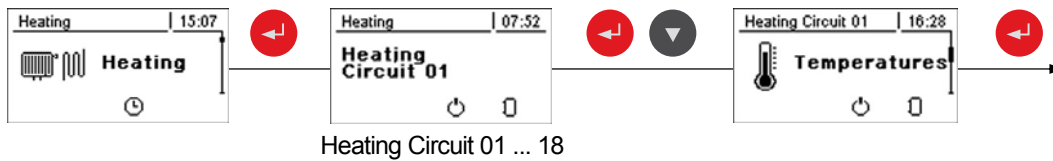

Setting value		Description
Desired room temperature during heating mode	22°C	For setting the desired room temperature for heating and setback mode. (Parameter only with optional remote control!)
Desired room temperature during setback mode	16°C	
Flow temperature SP at external temperature of +10°C	40°C	The heating curve to the relevant system can be adjusted with these two work points.
Flow temperature SP at external temperature of -10°C	60°C	

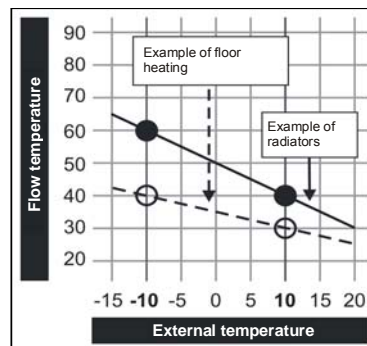

Setting value	Description
Controller gain room temperature Kp-Rm 6.0	Influencing factor of room temperature on the flow temperature of the heating circuit. If there is a deviation of the room temperature of $\pm 1^\circ\text{C}$ the set value of the flow temperature is corrected by this value. (Parameter only with optional remote control!) Recommended values for - Floor heating 2 – 3 - Radiators (new build): 4 – 5 - Radiators (old build): 6 – 7 + Notice: Observe external influences on the room sensors
Reduction of flow temperature in setback mode 15°C	The flow temperature is reduced by this value in the setback phase.
External temperature, at which heating circuit pump switches off in heating mode 18°C	If the external temperature exceeds this value during heating, the heating circuit pump and mixer are deactivated.
External temperature, at which heating circuit pump switches off in setback mode 7°C	If the external temperature falls below this value during setback mode, the heating circuit pump and mixer are activated.
Maximum flow temperature 75°C	Maximum temperature for limiting flow temperature.
Frost protection temperature 10°C	If the room temperature or the outfeed temperature is lower than the set value, the heating circuit pump will be switched on.

4.1.3 Heating times of the heating circuits

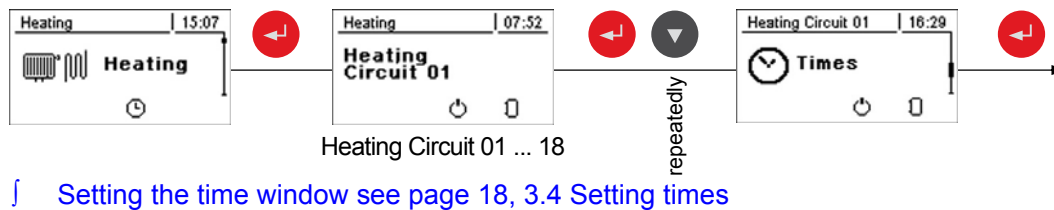

4.1.4 Service parameters for heating circuit

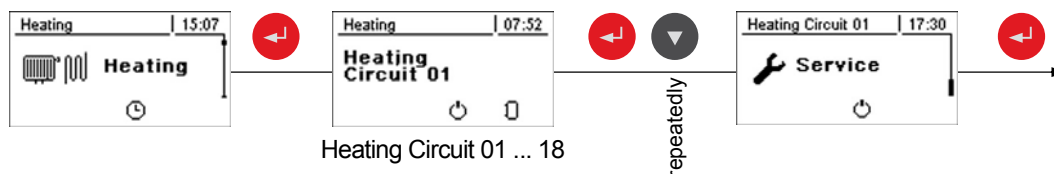

Parameter	Description
Heating circuit pump A 0	Used for testing the individual outputs.
Heating Circuit Mixer OPEN A 0	Page 38, 4.11 Menu - Manual
Heating Circuit Mixer CLOSED A 0	
Mixer runtime 240s	Set mixer runtime of heating circuit mixer in use.
Should this heating circuit heat when there is DHW tank priority NO	
From which storage tank or distributor is the heating circuit supplied (0 = boiler) 1	Notice: Only valid for multiple house systems Allocation of the heat source for this heating circuit. For standard systems the parameter is left as 1 0 = Boiler, 1 = storage tank 01, ...

4.2 Menu - Water

4.2.1 Status Displays for the DHW Tank

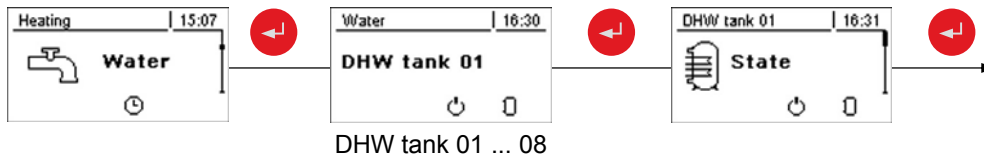

Display		Description
DHW tank top temperature	60°C	Current temperature in the top part of the DHW tank. The DHW tank is heated during the loading times until the specified parameter, "Desired DHW temperature", is reached.
DHW tank bottom temperature	55°C	Current temperature in the lower part of the DHW tank. (parameter only available with solar element).
DHW tank pump control	0%	Specifies the speed of the DHW tank pump as a percentage of maximum speed.

4.2.2 Temperature settings of the DHW tank

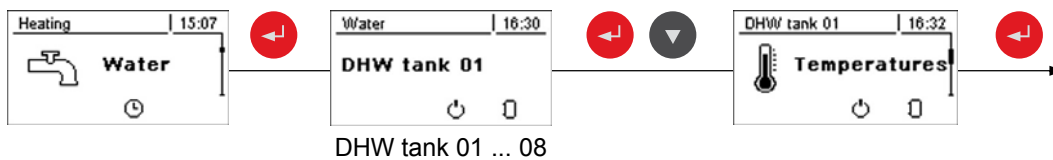

Setting value		Description
Desired DHW tank temperature	60°C	When the specified temperature is reached in the DHW tank, the DHW tank loading pump switches off.
Reload if DHW tank temperature is below	45°C	Reloading of the DHW tank is authorised when the DHW tank temperature is below this level.
Load if temperature difference between storage tank and DHW tank is	6°C	When the storage tank top temperature is above the DHW tank temperature by this value, the DHW tank loading pump is released.
Load if temperature difference between boiler and DHW tank is	6°C	Initial value of DHW tank loading. The boiler temperature must be higher than the DHW tank temperature by this value so that the DHW tank loading process begins.
Setpoint for temperature difference between boiler - DHW tank	10°C	Adjusting the boiler temperature setpoint to reach the desired DHW tank temperature. Boiler temperature setpoint = DHW tank temperature setpoint + Difference. If the boiler temperature setpoint is higher than the DHW temperature setpoint + difference, the boiler temperature setpoint is maintained.

4.2.3 Heating times of the DHW tank



Setting the time window see page 18, 3.4 Setting times

4.2.4 Service parameters of the DHW tank

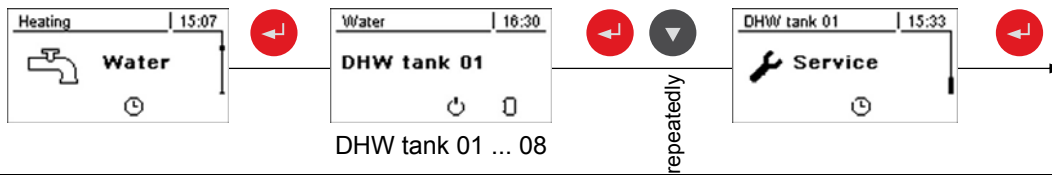

Parameter		Description
Residual heat use	NO	Function can only be used for systems without storage tank and in combination with bypass pump/ return feed mixer. Here the residual energy is diverted to the DHW tank, the parameter "Pumps start at" is ignored. The pump is controlled with minimum speed until the boiler temperature is lower than the DHW tank temperature + 3°C.
Only load DHW tank once a day	NO	If this parameter is set to "YES", repeated heating on one day is prevented.
Legionella heating activated	YES	The DHW tank is heated once a week to at least 65°C.
Which day for legionella heating	MO	Day of the week on which the Legionella heating is carried out.
Which storage tank or heat distributor supplies the heat (0 = boiler)	1	When using several storage tanks or heat distributors, the storage tank or heat distributor for DHW tank loading is selected here. If only one storage tank or heat distributor is used, leave the parameter on the standard setting of 1. + Notice: Only valid for multiple house systems
Minimum DHW pump speed	45%	Adjustment of the minimum speed to the pump type. + Notice: Always set the pump to the highest power level. (only switch the pump when it is disconnected from the power supply)
Which sensor is used for top DHW tank 1	0.3	Parameter display depends on the system. └ See "Lambdatronic P3200 Energy Systems"
Which pump is used for DHW tank 1	0.2	

4.3 Menu - Solar

4.3.1 Status displays for the solar system

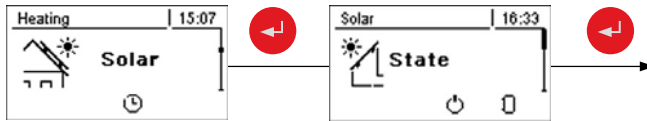

Display		Description
Collector Temperature	80°C	Current temperature at collector.
Solar temperature storage tank bottom	38°C	Current temperature at solar sensor in bottom storage tank.
DHW tank bottom temperature	39°C	Current temperature in the lower part of the DHW tank.
Collector pump runtime	1 h	Specifies the runtime of the collector pump.
Collector pump control	78%	Specifies the speed of the collector pump as a percentage of maximum speed.

4.3.2 Temperature settings for the solar system



Setting value		Description
DHW tank temperature setpoint during solar charging	75°C	Up to this temperature the DHW tank is heated by the solar system.
Temp differential to start collector pump	10°C	The collector loading pump activates when the collector temperature exceeds the storage or DHW tank temperature by this value.
Temp difference to stop collector pump	5°C	The collector loading pump activates when the collector temperature exceeds the storage or DHW tank temperature by this value.
Maximum storage tank bottom temperature during solar charging	85°C	Maximum bottom storage tank temperature at which the collector pump is switched off (only with storage tank).

4.4 Menu - Storage tank

4.4.1 Status display of the storage tank

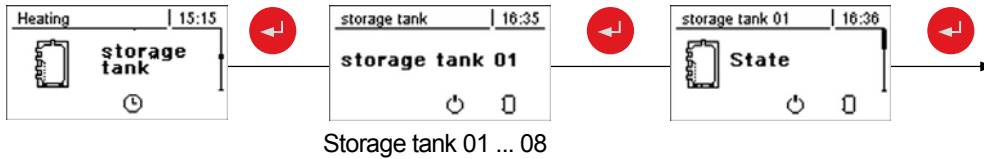

Display		Description
Storage tank top temperature	55°C	Current temperature at top storage tank sensor.
Storage tank middle temperature	53°C	Current temperature at middle storage tank sensor (depending on configuration).
storage tank bottom temperature	50°C	Current temperature at bottom storage tank sensor.
Pump control	0%	Specifies the speed of the storage tank pump as a percentage of maximum speed.

4.4.2 Temperature settings for storage tanks

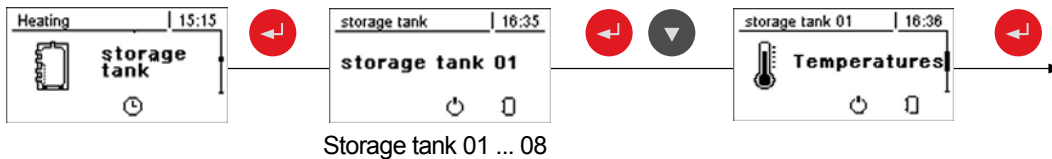

Setting value		Description
Heating circuit release from following storage tank temperature	30°C	Minimum value of storage tank top temperature for heating circuit release in combination with a storage tank.
Top storage tank minimum temperature - startup point	65°C	If the top storage tank temperature falls below this value, the boiler starts. Requirement: boiler is released by storage tank times.
Storage tank fully loaded if temperature difference Between boiler and bottom storage tank	10°C	From this temperature difference between the boiler temperature and the bottom storage tank temperature, storage tank loading is stopped.

4.4.3 Heating times of the storage tank

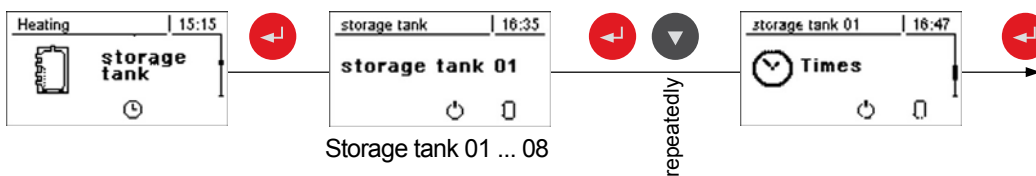

Setting the time window see page 18, 3.4 Setting times

4.4.4 Service Parameters for Storage Tank

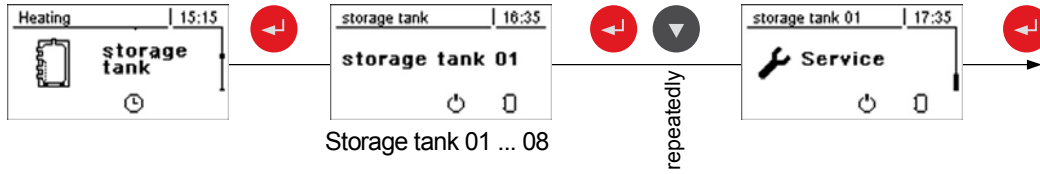

Parameter		Description
Minimum storage tank pump speed	45%	Adjustment of the minimum speed to the pump type. + Notice: Always set the pump to the highest power level. (only switch the pump when it is disconnected from the power supply)
Which sensor is used for storage tank top	0.1	Parameter display depends on the system.] See "Lambdatronic P3200 Energy Systems"
Which sensor is used for bottom storage tank	0.2	
Which pump is used for the storage tank	0.1	

4.5 Menu - Boiler

4.5.1 Status Displays for the Boiler

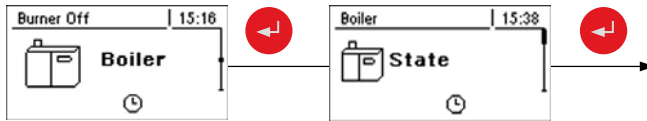

Display	Description
Boiler temperature 70°C	Display of the current values for the relevant parameter : :
Flue gas temperature 176°C	
Flue gas setpoint 178°C	
Boiler control variable 95%	
ID fan control 75%	
ID fan speed 2350U	
Air speed at suction opening 0.00 m	
Ignition pipe temperature 0°C	
Calculated boiler setpoint 70°C	
Sensor 1 85°C	

4.5.2 Temperature Settings for the Boiler

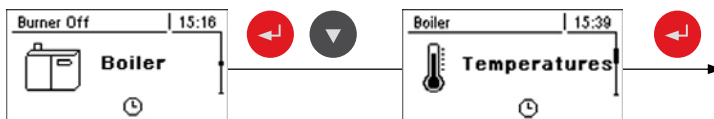

Setting value	Description
Boiler temperature setpoint 70°C	The boiler temperature is regulated to this value. (Range: 40 - 70 °C) Recommendation: System without storage tank 50°C, System with storage tank 70°C.
Shutdown if current boiler temperature is higher than boiler temperature setpoint + 15°C	If the boiler temperature exceeds the setpoint by this parameter value, the boiler switches to constant burn status. The boiler starts up again below the temperature setpoint.
Always switch off above highest possible boiler temperature setpoint + 3°C	If the boiler temperature exceeds the maximum setpoint by this parameter, the boiler switches to constant burn status. The heating circuit and store loading pumps will also begin to run to cool the boiler. The boiler starts up again below the temperature setpoint.
Minimum boiler temperature to release all pumps 35°C	The pumps are released at this boiler temperature. (Hysteresis 2°C).

Temperature in the STL housing at which all pumps run	80°C	If the temperature at the safety temperature limiter exceeds this value, all pumps are activated for heat emission.
Heating circuit excess in variable mode	2°C	If variable mode is activated, the boiler setpoint temperature in heating mode is increased by this value compared to the required flow temperature.

4.5.3 Service parameters of the boiler

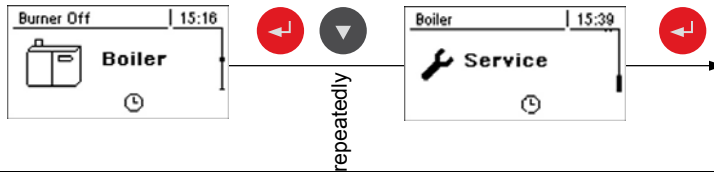

Parameter		Description
Variable mode activated	NO	The boiler temperature is controlled according to the calculated flow value for heating circuit/boiler.

4.6 Menu - Boiler 2

4.6.1 Status Displays for the Secondary Boiler

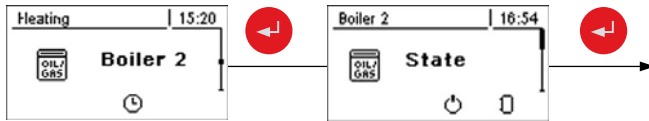

Display		Description
Boiler temperature	80°C	Display of the current boiler temperatures of the secondary boiler.
Burner relay status	0	Shows the current status of the burner relay.

4.6.2 Temperature Settings for the Secondary Boiler



Setting value		Description
Standby boiler start delay	60m	Start delay of the burner relay if the boiler fails (the boiler status is off, fault or shut down and the boiler temperature is 5°C below the setpoint). In storage mode the burner relay, however, only comes on when the storage tank has cooled down. (Top storage tank temperature is lower than the highest required temperature).
Standby boiler start, if storage tank top temperature is below	60°C	Temperature at top storage tank, which the temperature must fall below for the secondary boiler to be released.
Standby boiler minimum runtime	10m	Minimum runtime of the second boiler.
Minimum temperature of standby boiler	55°C	Minimum temperature of the second boiler for release of the boiler loading pump.
Temperature difference between standby boiler and storage tank	10°C	Minimum temperature difference between secondary boiler and storage tank, which releases boiler loading pump outlet.
Oil valve shut delay	30s	The switching back of the switch valve is delayed by the specified time.
Manual standby boiler start (only when ID fan is switched off)	OFF	Caution! Burner blockage noted.

4.6.3 Service Parameters for Secondary Boiler

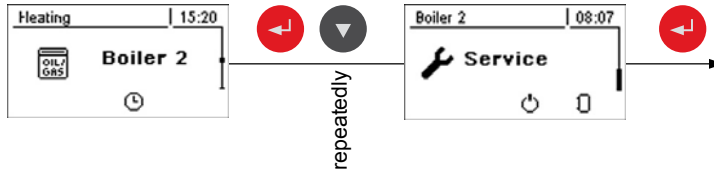

Parameter		Description
Control standby boiler variably to the setpoint	YES	If the secondary boiler has no independent control, the main control takes over the control of the boiler setpoints of the secondary boiler.
Which sensor is used for standby boiler	0.5	Bus address of the sensor used.] See 6.2.6 Setting the module address
Which output is used for unloading follow-up boiler	1.2] See "Lambdatronic P3200 Energy System"
Invert isolating valve	NO	For DHW tank loading through the secondary boiler, the switch valve is controlled with 230V. If the valve switches incorrectly, this parameter can be adjusted.
Which second Boiler is installed?	OIL BOILER	Boiler type of the secondary boiler: OIL BOILER MANUALLY FED AUT. FED GAS BOILER
Burner relays	A 0	

4.7 Menu - Pellets

4.7.1 Fuel Filling Times

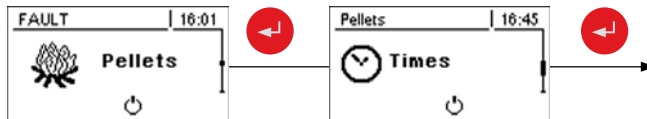

Setting value		Description
Start of 1st pellet filling	9:00	1st Start time for filling. This is only carried out if the fill level in the container is under 85%.
Start of 2nd pellet filling	15:00	2nd Start time for filling. This is also only carried out if the fill level in the container is under 85%.

4.7.2 Service Parameters for Fuel Feed



Setting value		Description
Refill of cyclone from	35%	Minimum fill level in day store / Start point of the pellet filling.

4.8 Menu - Network pump

4.8.1 Network Pump Status Displays

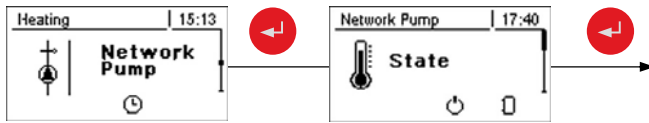

Display	Description
Network return temperature 0°C	Display of the current values for the relevant parameter Position of the sensors and pumps depending on the system used:] See diagrams for multiple house hydraulic systems (variants 1-5)
Network pump speed 100%	
Return temperature feeder 1 0°C	
Speed, feeder pump 1 0%	
Return temperature feeder 2 0°C	
Speed, feeder pump 2 0%	

4.8.2 Network pump temperature settings

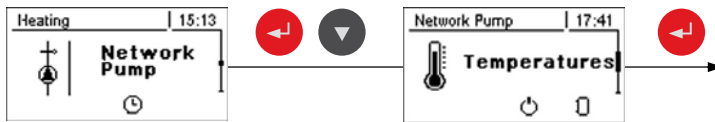

Setting value	Description
Network return setpoint 50°C	Setting for the desired network temperature setpoints. Position of the sensors depending on the system used:] See diagrams for multiple house hydraulic systems (variants 1-5)
Return temperature setpoint feeder 1 50°C	
Return temperature setpoint feeder 2 50°C	

4.8.3 Service parameters for the network pump

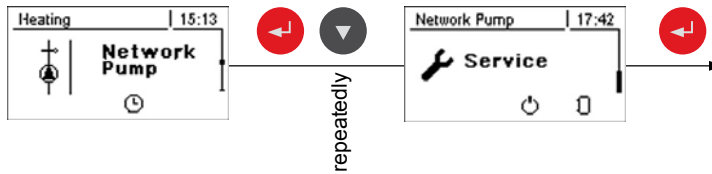

Parameter	Description
Minimum speed for network pump 45%	Adjusting the minimum speed to the relevant pump type. + Notice: Always set the pump to the highest power level. (only switch the pump when it is disconnected from the power supply)
Which sensor is used for the network return temperature 0.6	Bus addresses of the sensors used, depending on the system See 6.2.6 Setting the module address
Which pump is used for the network pump 0.2	See "Lambdatronic S 3200 Energy Systems"
Minimum speed for feeder pump 1 45%	Adjusting the minimum speed to the relevant pump type. + Notice: Always set the pump to the highest power level. (only switch the pump when it is disconnected from the power supply)
Which sensor is used for feeder 1 1.6	Bus addresses of the sensors used, depending on the system See 6.2.6 Setting the module address
Which pump is used for feeder 1 1.1	See "Lambdatronic S 3200 Energy Systems"
Minimum speed for feeder pump 2 45%	Adjusting the minimum speed to the relevant pump type. + Notice: Always set the pump to the highest power level. (only switch the pump when it is disconnected from the power supply)
Which sensor is used for feeder 2 2.6	Bus addresses of the sensors used, depending on the system See 6.2.6 Setting the module address
Which pump is used for feeder 2 2.1	See "Lambdatronic S 3200 Energy Systems"

4.9 Menu - Difference regulator (Differential temperature regulating output)

4.9.1 Status displays for the difference regulator

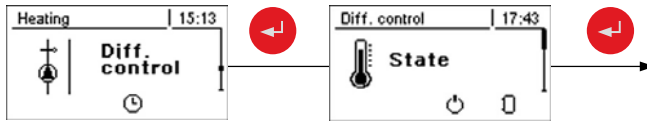

Display		Description
Heat source sensor	70°C	Current temperature of the heat source (heat distributor, e.g. storage tank)
Heat source sensor	60°C	Current temperature of the heat sink (user, e.g. DHW tank)
Pump speed	45%	Current pump speed

4.9.2 Temperature settings for the difference regulator

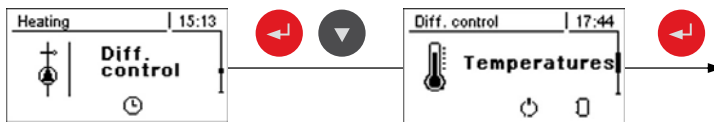

Setting value		Description
Startup difference	10°C	If the temperature of the heat source is higher than the heat sink is higher than the heat sink by the specified difference, the pump activates.
Shutdown difference	5°C	If the temperature difference between the heat source and the heat sink falls below this value, the pump is deactivated.
Minimum temperature for heat source	10°C	Temperature settings for regulating range of the differential temperature regulating output.
Maximum temperature for heat sink	100°C	The standard settings of 10°C or 100°C are selected so that the values in normal operation stay outside a limit.

4.9.3 Service Parameters for the Difference Regulator

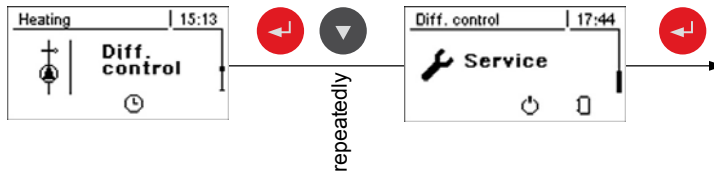

Parameter		Description
Minimum pump speed	45%	Adjusting the minimum speed to the relevant pump type. + Notice: Always set the pump to the highest power level. (only switch the pump when it is disconnected from the power supply)
Which sensor is used for the heat source	7.5	Bus addresses of the sensors used, depending on the system. └ See 6.2.6 Setting the module address └ See "Lambdatronic S 3200 Energy Systems"
Which sensor is used for the heat sink	7.6	
Which pump is used	7.2	

4.10 Menu - Circulation pump

4.10.1 Status displays for the circulation pump

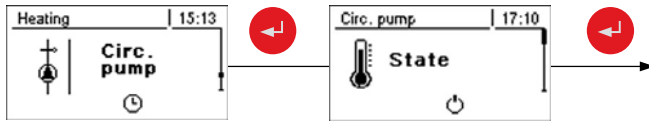

Display	Description
Return temperature in secondary circulation line 0°C	Shows the current temperature at the return feed sensor of the circulation line. + If the parameter "Return feed sensor present" is set to "NO", 0°C is permanently displayed.
Flow switch on the domestic hot water line 0	Shows the current status of the flow sensor: 0 ... no flow to the valve 1 ... Valve registers flow
Speed of the circulation pump 0%	Current circulation pump speed.

4.10.2 Temperature settings for the circulation pump

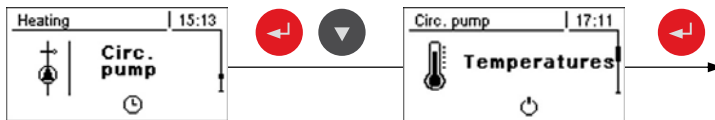

Setting value	Description
Return sensor present YES	YES The circulation pump is controlled according to time program and temperature at the sensor. In conjunction with the use of a flow valve, the circulation pump is also activated at a signal from the flow valve. NO The circulation pump is controlled according to time program. In conjunction with the use of a flow valve, the circulation pump is also activated at a signal from the flow valve. + Connect the flow sensor as the return feed sensor.
Switch off the pump at what return temperature in the circulation line 50°C	Parameter only relevant when a return feed sensor is used! If the set temperature at the return feed sensor is reached, the circulation pump shuts down.
Circulation pump last runnings 300s	Parameter only when a flow valve is used! If the flow valve does not register any more flow, the circulation pump carries on running for the time set.

4.10.3 Time setting for the circulation pump

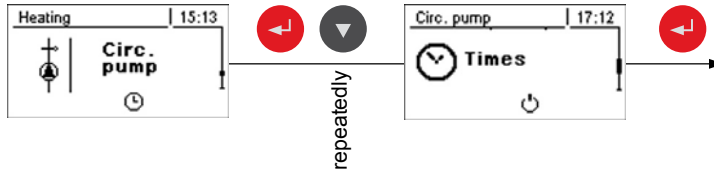

Setting the time window see page 18, 3.4 Setting times

4.10.4 Service parameters of the circulation pump

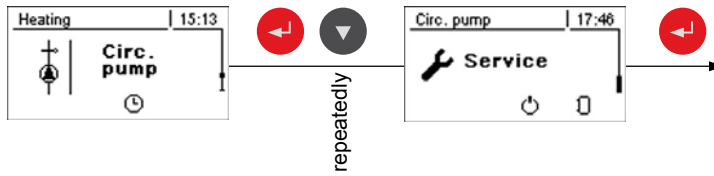

Parameter		Description
Which sensor is used for the circulation return feed	0.6	Bus addresses of the sensors and pumps used, depending on the system. See 6.2.6 Setting the module address See "Lambdatronic S 3200 Energy Systems"
Which sensor is used for the flow switch	1.5	
Which pump is used for the circulation	3.1	

4.11 Menu - Manual

4.11.1 Manual operation



Digital Outputs		
Manual Feed to Combustion Chamber	OFF	For manual fuel feed to burner. CAUTION: Overfilling hazard!
Ash Screw - Drive	OFF	Switching Relevant Unit On and Off
WOS - drive	OFF	
Ignition	OFF	
Burn back flap - drive	OFF	
Manual filling of pellet container	OFF	After activating the parameter, the container is filled with fuel, regardless of fill level, until the function is turned off or the switch point of the level sensors is reached. If a vacuum screw delivery system is installed, the screw is activated at defined intervals (15s on 15s off). The jam sensor is not analysed. When the level sensor reaches its limit value, the fill level value is set to 100%.
Grate - Drive	OFF	Open and close grate manually

4.11.2 Digital Outputs

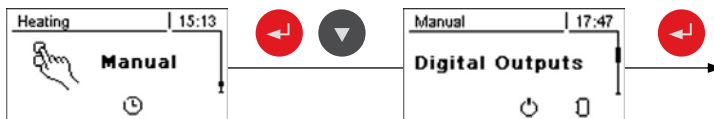

Digital Outputs		Description
Lambda probe heating	A 0	Used to test the digital outputs and is intended only for service technicians. The parameters displayed vary depending on the configuration.
Heating circuit pump 0	A 0	
Selection unit supply	A 1	
Open probe 1	A 1	A ... Automatic - A 0 ... Automatic, OFF - A 1 ... Automatic, ON
Open probe 2	A 0	
Open probe 3	A 0	0 ... Manual, OFF
Standby relay	A 0	1 ... Manual, ON
Ash Screw - Drive	A 0	
Pellet suction turbine	A 0	
WOS - drive	A 0	

4.11.4 Digital Inputs

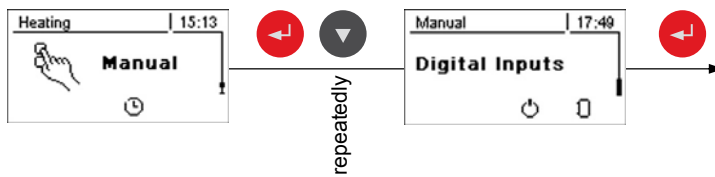

Digital Inputs		Description
Door switch	A 0	Used to test the digital inputs and intended only for service technicians. The parameters displayed vary depending on the configuration.
STL input	A 0	
EMERGENCY OFF input	A 0	A ... Automatic - A 0 ... Automatic, OFF - A 1 ... Automatic, ON
Boiler enable	A 0	
MAX level	A 0	0 ... Manual, OFF 1 ... Manual, ON
Jam sensor	A 0	
Back burn slide valve closed	A 0	
Back burn slide valve open	A 0	
Grate open	A 0	
Grate closed	A 1	
MIN level	A 0	
Combustion chamber overpressure sensor inputs	A 0	
Motor protection switch delivery screw	A 0	
PM power supply over current switch	A 0	
PM power supply over current warning	A 0	
PM suction unit active	A 0	
PM Dig. IN res 2	A 0	

4.12 Menu - System

4.12.1 Adjustable parameters

Adjustable Parameters - Boiler Temperature

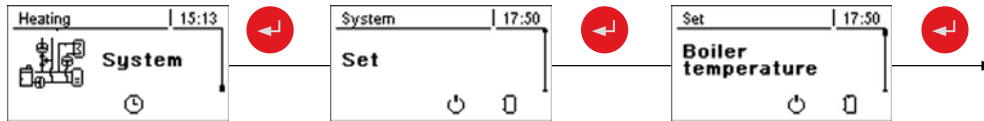

Parameter	Description
Boiler temperature setpoint 50°C	The boiler temperature is regulated to this value. (Range: 40 - 70 °C) Recommendation: System without storage tank 50°C, System with storage tank 70°C.
Shutdown if current boiler temperature is higher than boiler temperature setpoint + 15°C	If the boiler temperature exceeds the setpoint by this parameter value the boiler follows the shutdown procedure. If the boiler temperature is above the setpoint after shutdown the boiler changes to constant burn status. The boiler starts up again below the temperature setpoint.
Always switch off above highest possible boiler temperature setpoint + 3°C	If the maximum boiler temperature setpoint is exceeded by this parameter the boiler carries out the shutdown procedure. The heating circuit and store loading pumps will also begin to run to cool the boiler. The boiler starts up again below the temperature setpoint.
Boiler temperature to release all pumps 35°C	The pumps are released at this boiler temperature. (Hysteresis 2°C).
Temperature in the STL housing at which all pumps run 80°C	If the temperature at the safety temperature limiter exceeds this value, all pumps are activated for heat emission.
Heating circuit excess in variable mode 2°C	If variable mode is activated, the boiler setpoint temperature in heating mode is increased by this value compared to the required flow temperature.

Adjustable Parameters - Flue Gas

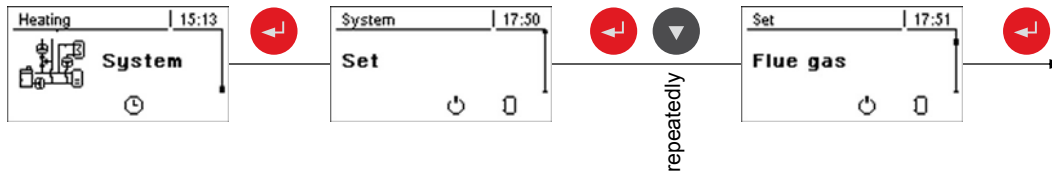

Parameter	Description
Minimum flue gas temperature 100°C	Min. setpoint for the flue gas temperature. Lowest load point for continuous operation. See 4.13 Boiler Type-Related Factory Settings
Maximum flue gas temperature 250°C	Max. setpoint for the flue gas temperature. Highest load point for sufficiently good degree of efficiency.
Boiler output from a flue gas temperature of 20°C 50%	Value, by which the flue gas temperature setpoint is increased when heating up.

Parameter	Description
100% boiler output from a flue gas temperature of 100°C	If the flue gas temperature is above the specified setpoint, fuel output should reach 100% (upper point of the start ramp).
Minimum difference between flue gas temperature and boiler temperature 10°C	If, in "Heating" status, the difference between flue gas temperature and boiler temperature falls below the set value, the system registers an error after the safety time has elapsed.
Flue gas - flue gas difference 10°C	If, after heating up, the flue gas temperature is higher than before the heating up phase by this value, the controls change to "heating" status.
Safety time 8m	If, at "Heating" status, the minimum flue gas-boiler difference shutdown condition is not reached for this time, the boiler switches to the status, "Safety time elapsed, flue gas temperature too low for too long".

Adjustable Parameters - Ignition

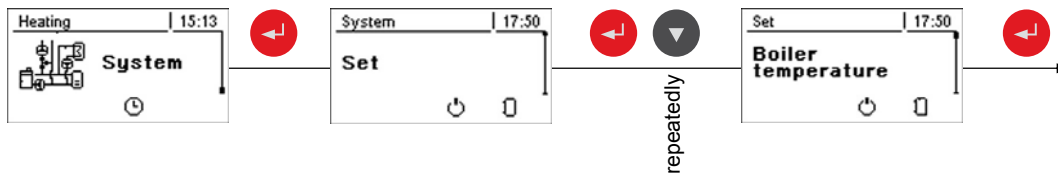

Parameter	Description
Duration of preheating 260s	Duration of pre-heating phase. No pellets are fed in. See 4.13 Boiler Type-Related Factory Settings
Maximum ignition time 10m	Time within which the boiler must change from "Ignition" status to "Heating" status. If the required flue gas temperature is not reached during this time, a fault is displayed.
Loading time without ignition 75s	Specifies how long fuel is fed in before "Preheating" status. See 4.13 Boiler Type-Related Factory Settings
Loading during ignition 50%	Pellet loading in "Ignition" status. See 4.13 Boiler Type-Related Factory Settings

Adjustable Parameters - Air Settings

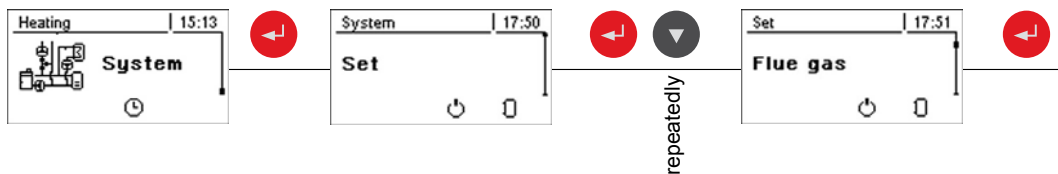

Parameter	Description
Minimum ID fan speed 35%	Minimum ID fan speed
ID fan min 16%	Base point for setting the ID fan characteristic line
ID fan max 65%	End point for setting the ID fan characteristic line See 4.13 Boiler Type-Related Factory Settings
ID fan during heating up 60%	ID fan speed in the relevant operating statuses
ID fan during pre-heating 60%	
ID fan during shutdown 65%	

Parameter	Description
ID fan during Ignition	60%

Adjustable Parameters - Pellet loading

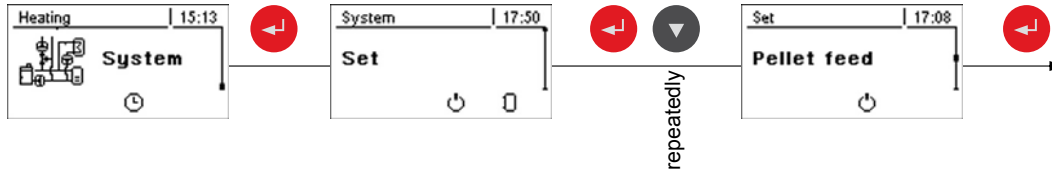

Parameter	Description
Maximum loading rate	100% Loading in percent at maximum boiler output.
Minimum loading rate	20% Minimum loading of stoker screw. See 4.13 Boiler Type-Related Factory Settings
Shutdown wait 1	15m During this time period the boiler is ventilated by the ID fan.
Shutdown wait 2	5m Time between the statuses Shutdown wait 1 and cleaning.
WOS runtime	60s Runtime of heat exchanger cleaning.
Cycle of ash screw	1000 The ash screw is activated in the defined cycle. The cycle is calculated from the runtime of the stoker screw.
Runtime of the ash screw	70s After the cycle of the ash discharge unit has ended, the ash screw is controlled for this runtime.
Number of shutdowns to activate cleaning	5 Specifies how many times the system shuts down without carrying out cleaning.

Adjustable Parameters - Chamber Delivery Unit

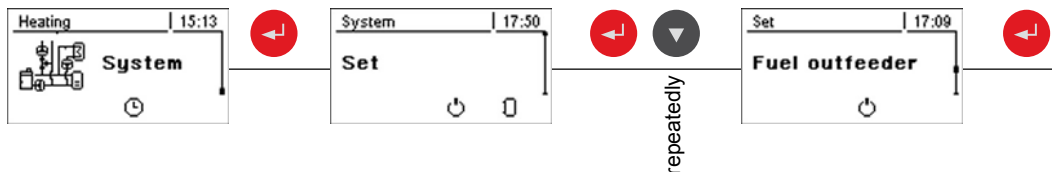

Parameter	Description
Start of 1st pellet filling	09:00 1st Start time for filling. This is only carried out if the fill level in the container is under 85%.
Start of 2nd pellet filling	15:00 2nd Start time for filling. This is also only carried out if the fill level in the container is under 85%.
Refill of cyclone from	35% Minimum fill level of the cyclone container. If the level falls below this value pellet filling starts.
Maximum time until switching of probe	10m Time period, during which the pellet container must reach a fill level of 100% from a probe. If this time is exceeded, the Komfort pellet box automatically changes to the next probe. When using the Eco pellet box an error message is displayed.
Gate valve present	YES Sealing slider on cyclone lid. Used to close the suction line and the return line for pellet feed.
Measured path of gate valve	75% This is the actual path of the gate valve, which is measured when the system is switched on. When the power is switched off the path is measured again.

Parameter	Description
Minimum path for gate valve 70%	This parameter is automatically set 5% below the measured path at initial startup.

Adjustable Parameters - Lambda Values

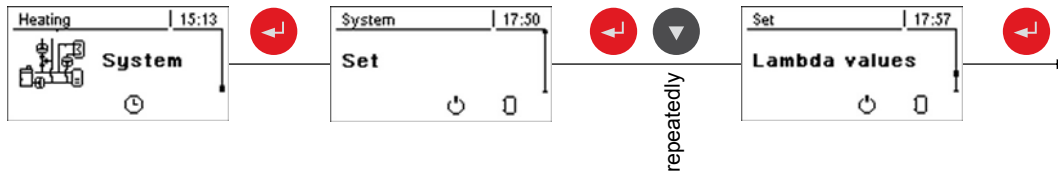

Parameter	Description
Residual oxygen content setpoint 9.0%	Combustion is regulated according to this setpoint. See 4.13 Boiler Type-Related Factory Settings
No loading when residual O2 below 4.5%	No pellets are loaded below this value.
Residual oxygen content, above which fire is out 19.5%	If the residual oxygen content in "heating" status goes above this value, the control goes to "Fault" status after the safety time. The fault "Safety time O2 too high" is displayed.
O2 Controller max 120%	Factory setting - do not alter!
Influencing factor for O2 controller 1.5	Factory setting - do not alter!
Air quantity, which should be reached during preparation with P4 1.50m	Minimum value [m/s], which should be reached at the flow sensor. See 4.13 Boiler Type-Related Factory Settings

General Settings

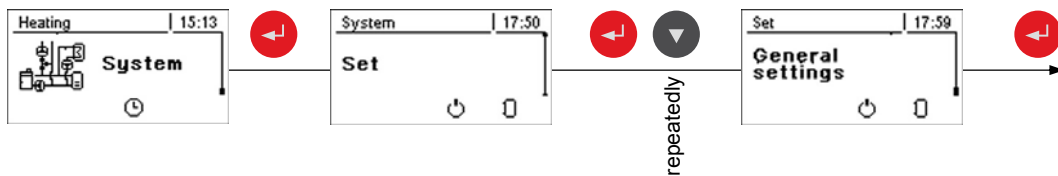

Parameter	Description
Adopt boiler standard values NO	If this parameter is set to "YES", the current parameters for the selected boiler are set. After the values have been adopted the parameter jumps back to "NO".
Modem installed NO	If the boiler has a modem for data transfer, this value must be set to "YES".
Memory cycle of data logger 5s	Leave the value! This is the memory cycle used for saving data on the data logger.

4.12.2 Current system values



Current value		Description
Boiler temperature	70°C	Display of the current values for the relevant system parameter : :
Flue gas temperature	90°C	
Flue gas setpoint	120°C	
Boiler control variable	99%	
ID fan control	75%	
ID fan speed	2230U	
Residual oxygen content	12.3%	
Oxygen control	68%	
Feed	52%	
Fill level in pellet container	99%	
Air speed at suction opening	0.00 m	
Pellet module board temperature	29°C	
Delivery screw power input	0.00A	
Gate valve position	0%	
Calculated boiler setpoint	50°C	
External temperature	23°C	
Board Temperature	33°C	
Number of burner starts	1	
Service hours	26h	
Software version	Version: 50.04 Build: 04.11	

4.12.3 Error list

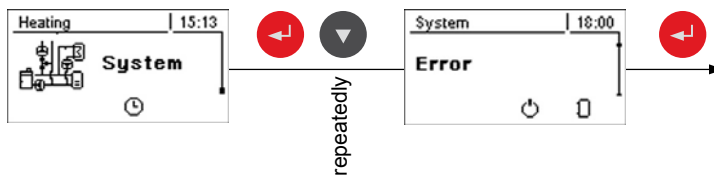

For procedure for faults see page 49, 5.1 Error display

4.12.4 Parameters for sensors and pumps

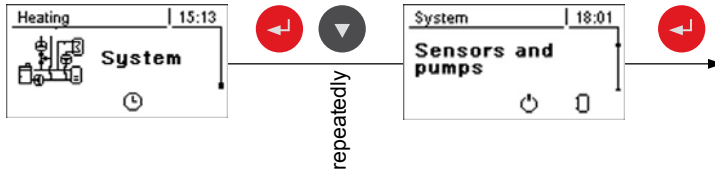

Parameter	Description
Which sensor is used for storage tank top 0.1	Setting the bus addresses of the sensors and pumps used. See 6.2.6 Setting the module address The display of the parameters varies depending on the system set. See "Lambdatronic P3200 Energy Systems"
Which sensor is used for bottom storage tank 0.2	
Which pump is used for the storage tank 0.1	
Which sensor is used for standby boiler 0.5	
Which sensor is used for standby boiler Pump 1	
Which sensor is used for the storage tank reference 0.2	
Which pump is used for the solar collector 1.1	
Which pump is used for the solar isolating valve 1.2	
Which sensor is used for top DHW tank 1 0.1	
Which sensor is used for bottom DHW tank 1 0.2	
Which pump is used for DHW tank 1 0.1	

4.12.5 Operating rights and allocations for displays

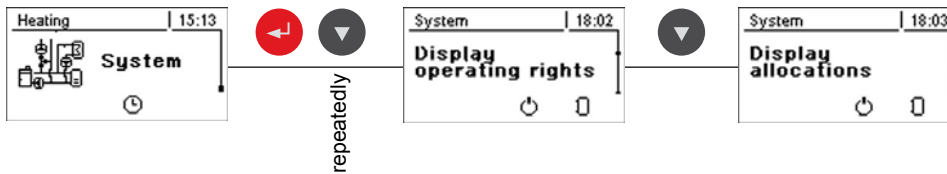

+ This is set by Fröling factory customer services at initial startup.

4.12.6 Basic display parameters

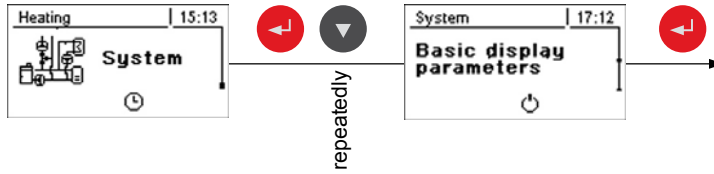

Basic display		Description
	<p>Position 1</p> <p>Position 2</p>	<p>The display of the two positions in the basic display can be adjusted individually, and for each position you can choose from the following parameters:</p> <p><i>Boiler, flue gas, external, room, DHW tank, storage tank top, storage tank bottom, storage tank graphic, residual O2, ID fan.</i></p>

4.12.7 Set mode

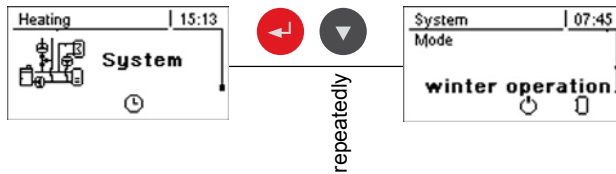

See from page 16, 3.2.2 Start boiler

4.12.8 Language Settings

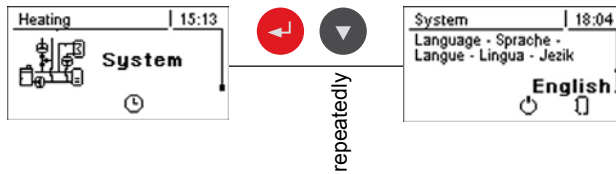

To change the current menu language (only with installer code).

4.12.9 Time settings

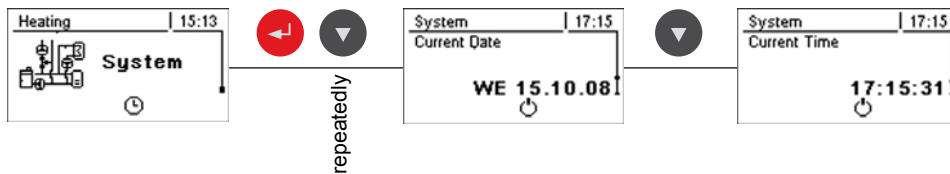

4.12.10 Standard settings

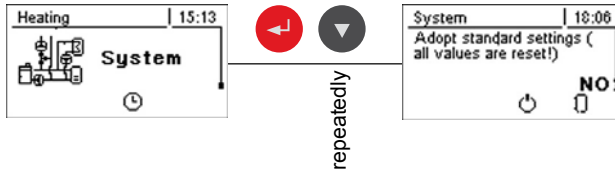

- + Adopting standard factory settings. This resets all parameters! After resetting the parameters for the boiler must be reset or else boiler functioning is no longer guaranteed. (only with service code).

4.12.11 Current User Level



Changing the current operating level see 12, 3.1.1 Changing the Operating Level

4.12.12 System parameters



Changing the current system parameters see page 13, 3.1.2 Setting the System Type

4.13 Boiler Type-Related Factory Settings

Parameter	Unit	P4 Pellet					
		8	15	20	25	32	38
Minimum flue gas temperature	°C	100	100	100	100	100	100
Duration of pre-heating	s	260	260	260	260	280	280
Loading time without ignition	s	75	75	75	75	75	75
Loading during ignition	%	50	50	40	40	25	25
Minimum loading rate	%	20	20	16	16	12	12
ID fan max	%	55	65	55	65	55	65
Residual oxygen content setpoint	%	9.0	9.0	9.0	9.0	8.0	8.0
Air quantity, which should be reached during preparation	m	1.0	1.0	2.0	2.0	1.4	1.4

5 Troubleshooting

5.1 Error display



When a fault occurs:

- The status LED (1) flashes red
- In the graphic display the fault message number is displayed with the relevant error description
- The “caution” symbol is also shown in the display

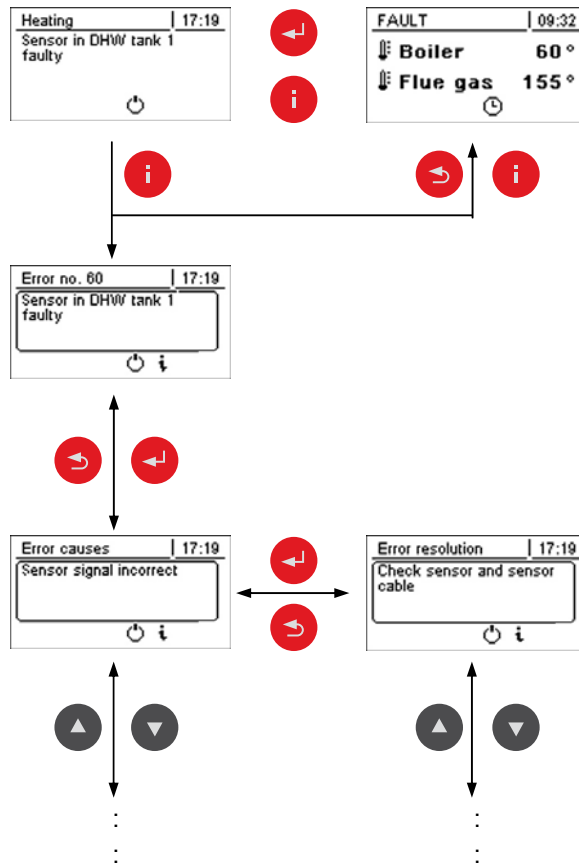

After pressing the enter key the fault is acknowledged. The warning symbol in the status line shows that the error is still pending.

Pressing the info key displays the error as info text with the related error number. The warning symbol only switches off when the error has been resolved!

After pressing the enter key an info text on the cause of the error is displayed. Pressing the enter key again displays instructions for resolving the error.

If an error has various causes or a cause can be resolved in various ways, you can scroll through with the navigation keys.

Connection	Cable dimensions / Specifications / Notice
COM 1	Null modem cable 9-pin SUB-D
Lock	Connection cable ¹⁾ 2 x 0.75 mm ²
EMERGENCY OFF	Connection cable ¹⁾ 2 x 0.75 mm ² + Caution! Do not connect the emergency off/ emergency stop switch to the 230V power supply cable of the boiler. The switch must be a N/C switch and it must be linked to the 24V safety chain of the STL at this terminal.
Boiler release	Connection cable ¹⁾ 2 x 0.75 mm ² + Caution! The connection must be a floating connection.
External sensor	Connection cable ¹⁾ 2 x 0.75 mm ² , from 25m cable length shielded
Room sensor 1/2	Connection cable ¹⁾ 2 x 0.75 mm ² , from 25m cable length shielded
Outfeed sensor 1/2	Connection cable ¹⁾ 2 x 0.75 mm ² , from 25m cable length shielded
Pump 1 on core module	Connection cable ¹⁾ 3 x 1.5 mm ² , max. 1,5A / 280W / 230V
Mains	Connection cable ¹⁾ 3 x 1.5 mm ² ; fused with max. 16A (provided by the customer)
Mixer 1/2	Connection cable ¹⁾ 4 x 1.5 mm ² , max. 0.2A / 230V
Heating circuit pump 1/2	Connection cable ¹⁾ 3 x 1.5 mm ² , max. 2.5A / 230V / 500W
Heating circuit pump 0	Connection cable ¹⁾ 3 x 1.5 mm ² , max. 3A / 600VA

1) YMM as per ÖVE-K41-5 or H05VV-F as per DIN VDE 0881-5

6.1.2 Mains connection

Connect the power supply at the “Mains connection” (1) plug

- + Flexible sheathed cable should be used for the wiring which should be measured in compliance with the applicable regional standards and guidelines
- + The power supply line (mains connection) must be fitted with a 16 A fuse at the place of installation. If a safety overload switch is used it should be a type with 16A and “Tripping Characteristic C”.



6.1.3 Connecting the Flue Gas Sensor

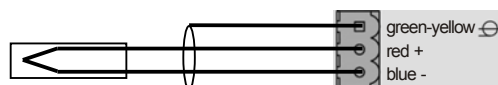

Core module

6.1.4 Combination with Oil Burner

The connection "Heating circuit pump 0" can be used for heating circuit pump 0 or as burner relays depending on the system setting.

1. Connecting a HCP 0 up to max. 2 Ampere:

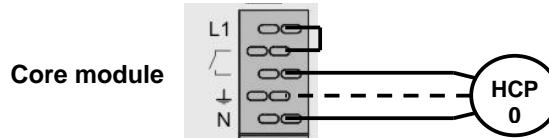

2. Connecting a HCP 0 up to max. 5 Ampere:

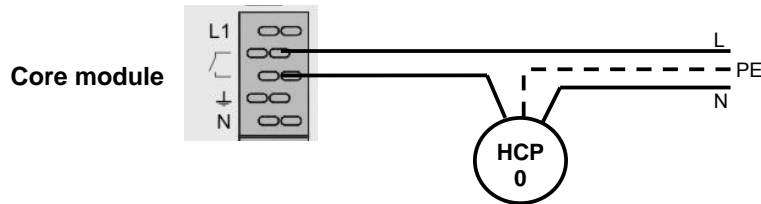

3. Connection as burner relays:

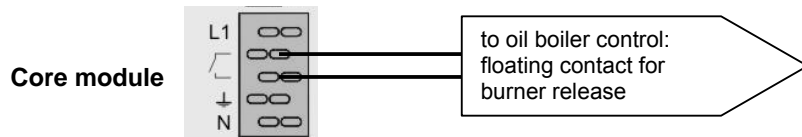

6.1.5 Connecting the remote control

A room sensor is included in the remote control, which sends the current room temperature to the control.

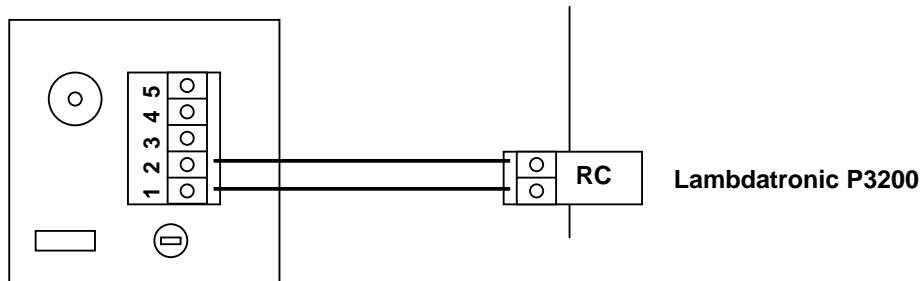

Switch settings:

- * ... **Override circuit:** ignores the setback
- ⌚ ... **Automatic mode** Heating phases according to setback program
- ☾ ... **Setback mode** ignores the heating phases
- Handwheel ... Allows you to adjust the temperature by $\pm 3^{\circ}\text{C}$

6.1.6 Boiler release input

When setting the system selection, the parameter “Boilerlaunch in av” is preset to enable an external floating release or start contact.

Boiler enable input available YES

This is set if boiler release input is available.

Provided the contact is closed, the controls regulate according to the specified mode. If the external contact is opened, the boiler loses its release and follows the shutdown procedure.

As soon as the handle is opened the controls do not accept any heat requirements.

(e.g. flue gas thermostat of a supply boiler)

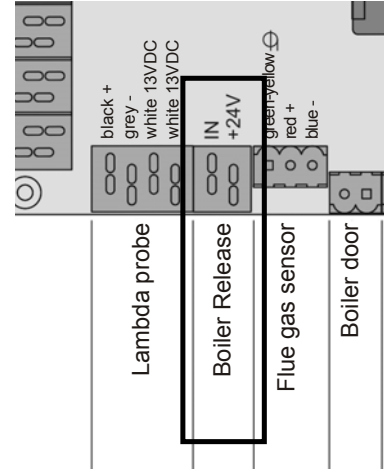

Boiler enable input available NO

This is set if there is a boiler start input or no layout.

As long as the contact is open, the controls operate according to the specified parameters. If the external contact is closed, starts the boiler and works in continuous operation.

(e.g. heat requirements of a heating fan)

Notice: No handle required for operation.

- + If the boiler is released or started by the parameter, it goes at least to “Heating” status, even if meanwhile the signal has stopped. When this has been carried out, the boiler follows the shutdown procedure.

6.1.7 Error message switch

Two floating switch contacts are available (“normal open” and “normal closed”) for control of external warning devices (signal lights, signal horn, SMS box, ...).

If a fault occurs both contacts are activated, and the “normal open” closes and the “normal closed” opens.

- + Maximum load of the contact: 1A

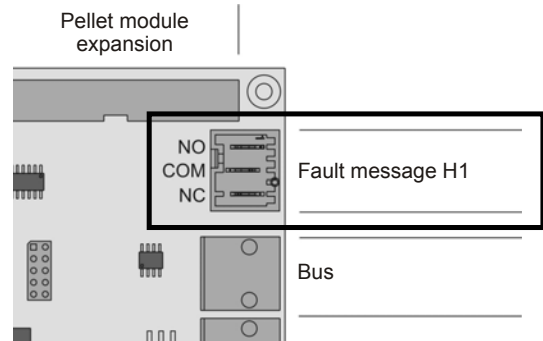

6.2 Expansion modules

6.2.1 Heating circuit module

Two heating circuits can be controlled as standard with the core module.

To extend the heating circuit control, the heating circuit module boards must be extended. It is possible to expand by eight heating circuit modules (addresses 0 to 7), and the correct setting of the module address must be observed.

└ Page 58, 6.2.6 Setting the module address

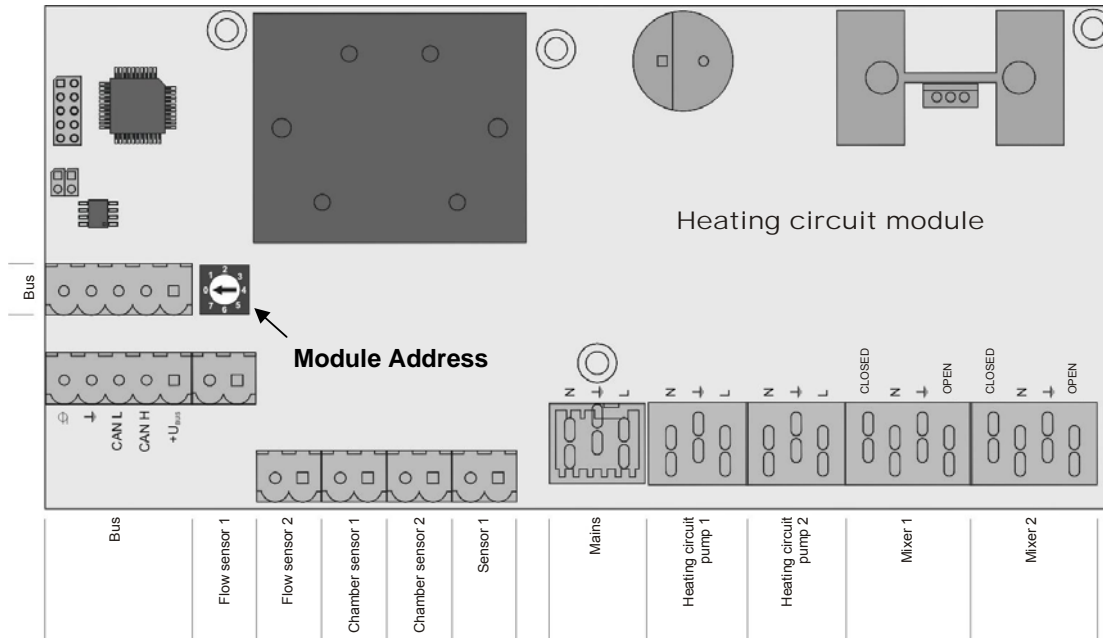

Connection instructions

Connection	Cable dimensions / Specifications / Notice
Bus	Connection with cable - LIYCY paired 2x2x0.5; └ Connecting the bus cable see 6.2.5 Connecting the bus cable + Caution! CAN L and CAN H should not be connected with +U_{BUS}.
Outfeed sensor 1/2	Connection cable ¹⁾ 2 x 0.75 mm ²
Room sensor 1/2	Connection cable ¹⁾ 2 x 0.75 mm ² , from 25m cable length shielded
Mains	Connection cable ¹⁾ 3 x 1.5 mm ² ; fused 10A
Heating circuit pump 1/2	Connection cable ¹⁾ 3 x 1.5 mm ² , max. 2.5A / 230V / 500W
Mixer 1/2	Connection cable ¹⁾ 4 x 1.5 mm ² , max. 0.2A / 230V

1) YMM as per ÖVE-K41-5 or H05VV-F as per DIN VDE 0881-5

6.2.2 Hydraulic System Module

The hydraulic system module makes available the connections of sensors and pumps for the hydraulic components of the system (storage tank, DHW tank ...). A hydraulic module is included in the delivery as standard. A further seven modules can be installed later. The module address should be allocated correctly.

└ Page 58, 6.2.6 Setting the module address

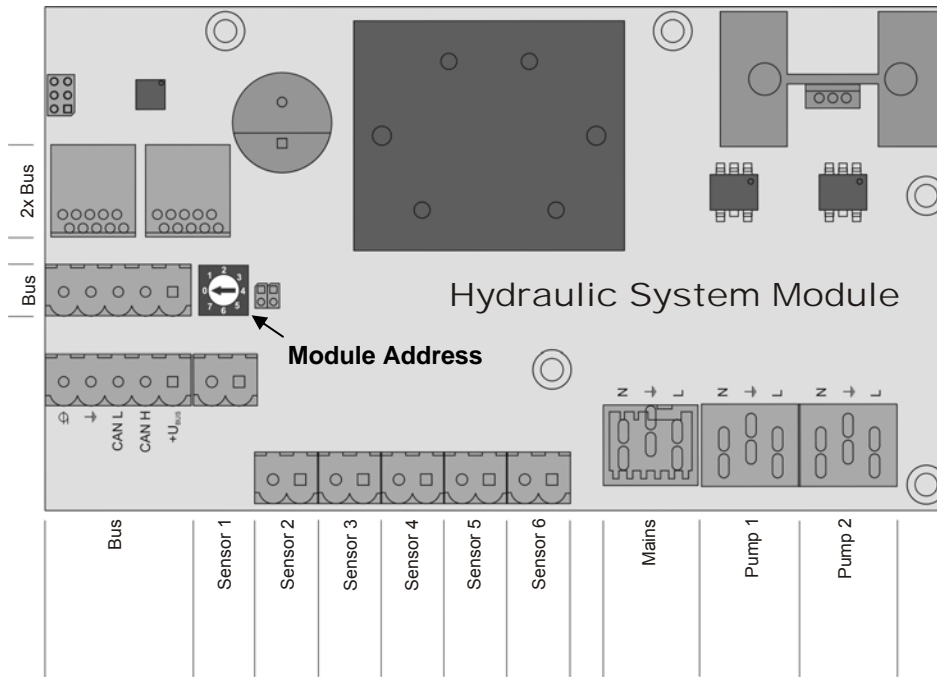

Connection instructions

Connection	Cable dimensions / Specifications / Notice
2 x Bus	Patch cable CAT 5 RJ45 SFTP 1:1 layout
Bus	Connection with cable - LIYCY paired 2x2x0.5; └ Connecting the bus cable see 6.2.5 Connecting the bus cable + Caution! CAN L and CAN H should not be connected with +U_{bus}.
Sensors 1 - 6	Connection cable ¹⁾ 2 x 0.75 mm ² , from 25m cable length shielded
Mains	Connection cable ¹⁾ 3 x 1.5 mm ² ; fused 10A
Pump 1/2	Connection cable ¹⁾ 3 x 1.5 mm ² , max. 1.5A / 230V / 280W

1) YMM as per ÖVE-K41-5 or H05VV-F as per DIN VDE 0881-5

6.2.3 Pellet module

The pellet module is included in standard delivery and has the connections of the hardware components for the pellet feed and pellet combustion:

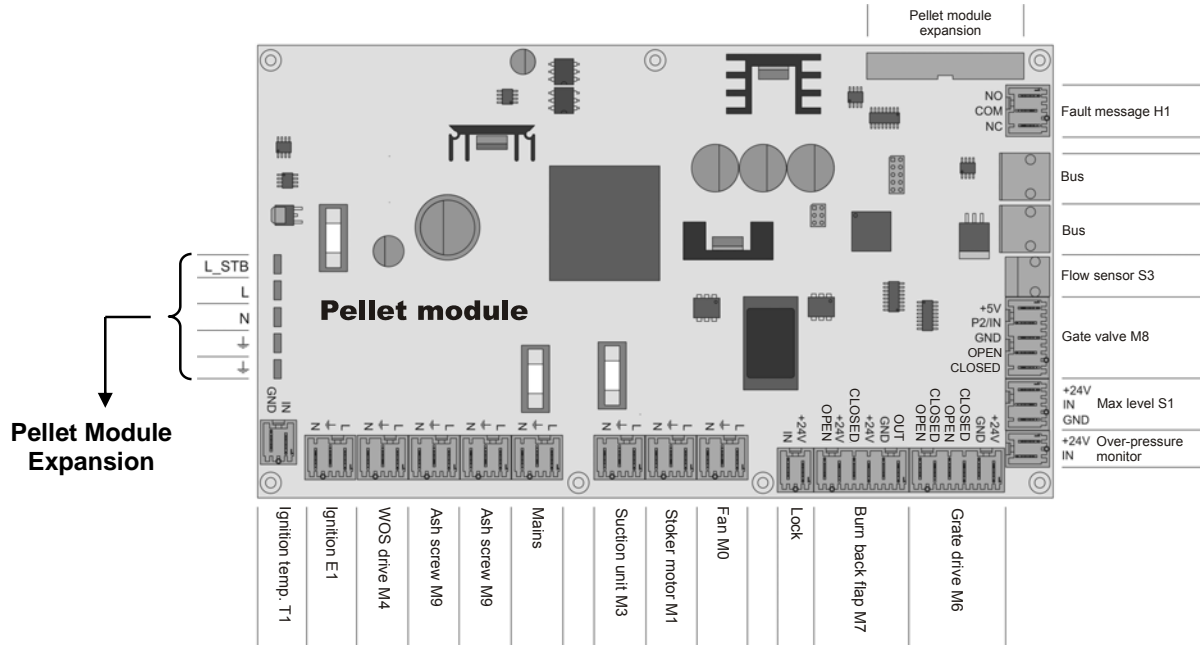

Connection instructions

Connection	Cable dimensions / Specifications / Notice
Mains	Connection cable ¹⁾ 3 x 1.5 mm ² ; fused 10A
Lock	Connection cable ¹⁾ 2 x 0.75 mm ² , connection of the key switch in series
2 x Bus	Patch cable CAT 5 RJ45 SFTP 1:1 layout
Fault message	Connection cable ¹⁾ 3 x 1.5 mm ² , max. 1A

1) YMM as per ÖVE-K41-5 or H05VV-F as per DIN VDE 0881-5

6.2.4 Pellet Module Expansion

A suction delivery unit is used as standard with the pellet module. The pellet module expansion is required if suction screw systems or other delivery systems or system components from other manufacturers are used.

The power supply line and the communication line must be linked to the pellet module.

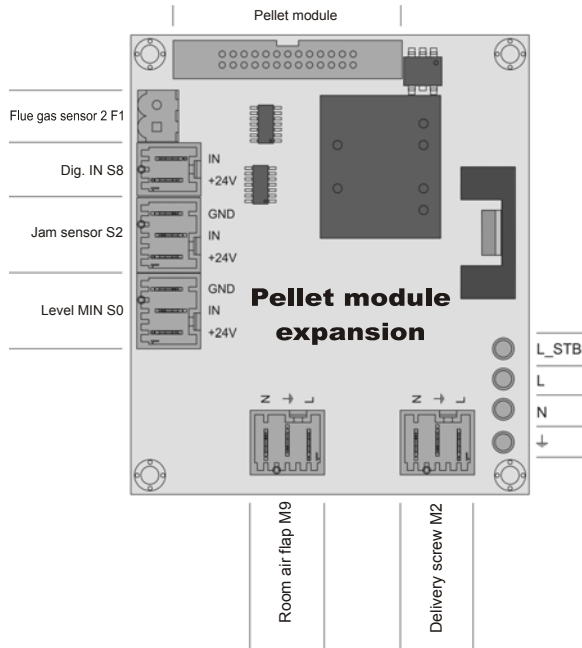

Connection Diagram:

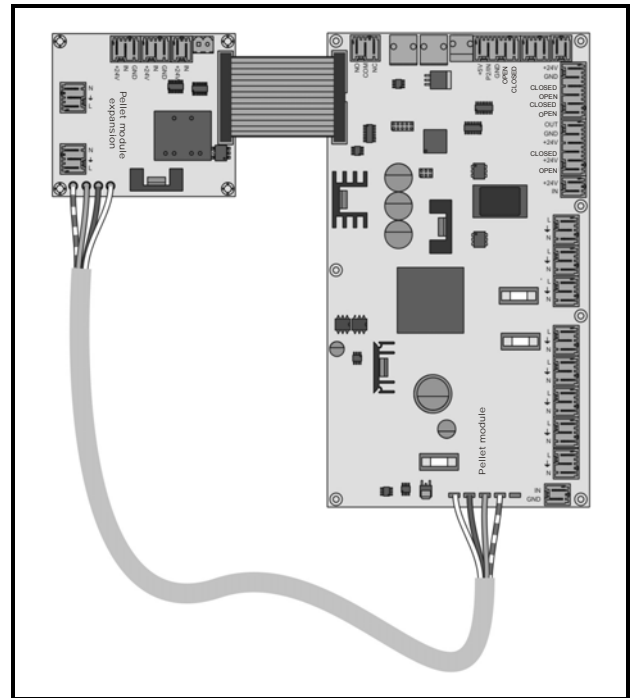

Connection instructions

Connection	Cable dimensions / Specifications / Notice
Dig.IN S8	Connection cable ¹⁾ 2 x 0.75 mm ² , 24 VDC
Room air flap	Connection cable ¹⁾ 3 x 1.5 mm ² , max. 1A / 230V
Delivery screw	Connection cable ¹⁾ 3 x 1.5 mm ² , max. 4A / 230V / 900W

1) YMM as per ÖVE-K41-5 or H05VV-F as per DIN VDE 0881-5

6.2.5 Connecting the bus cable

For the bus connections between the individual modules, you should use a type **LIYCY paired 2x2x0.5** cable. The connection to the 5-pin plugs should be carried out according to the following diagram:

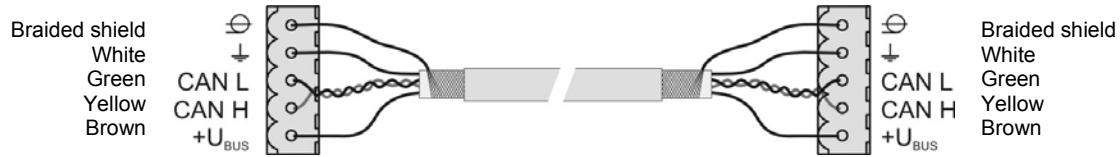

6.2.6 Setting the module address



For hydraulic system modules or heating circuit modules it is necessary to set the necessary order with the module addresses. The first board of a module type should always have the address 0, so that the standard hydraulic systems set do not have to be subsequently configured. For further module types rising module addresses (1 to 7) are set.

A hydraulic system module with address 0 is included in standard delivery. If a second hydraulic system module is also installed, address 1 is set.

Example - heating system with 1 storage tank, 1 DHW tank and 6 heating circuits:

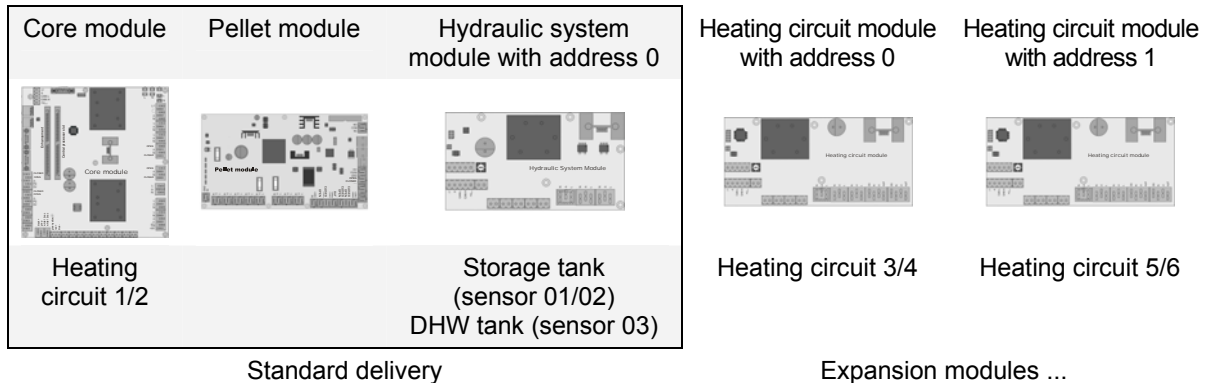

Set Module Address	Heating circuit module	Hydraulic System Module	
	Heating circuit	Sensor	Pump
0	03 - 04	01 .. 06	01 - 02
1	05 - 06	11 .. 16	11 - 12
2	07 - 08	21 .. 26	21 - 22
3	09 - 10	31 .. 36	31 - 32
4	11 - 12	41 .. 46	41 - 42
5	13 - 14	51 .. 56	51 - 52
6	15 - 16	61 .. 66	61 - 62
7	17 - 18	71 .. 76	71 - 72

6.2.7 Setting end jumper

To ensure smooth running of the bus system, both jumpers (J) must be set on the last module.

- + The jumpers are placed at the hydraulic system module in standard delivery. They should be removed in case of an expansion.

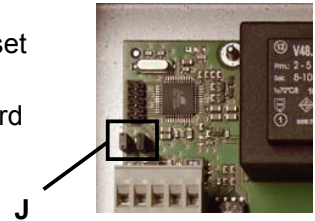

6.3 Universal suction system

With the automatic universal suction system, the Komfort pellet box is linked to the core module using flexible cable (5x0.75mm², e.g. YMM as per ÖVE-K41-5 or H05VV-F as per DIN VDE 0281-5). 24 V control cable is used.

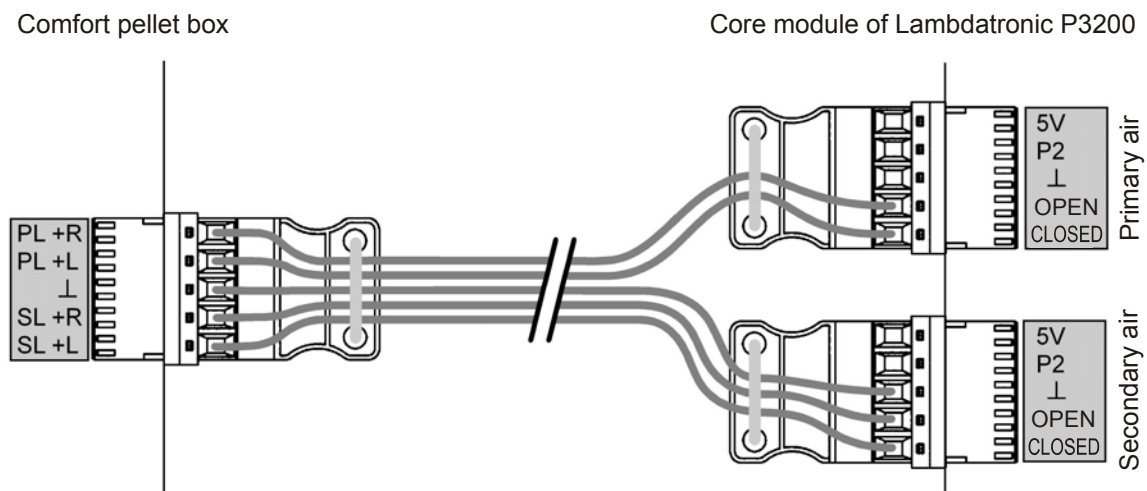

The previous illustration shows the 5-pin connection plug of the Komfort pellet box in direction of connection and the accompanying connection layout to the Lambdatronic P3200 control system.

To check the plug arrangement:

- ρ Detach the protective plate (1) from the board.
- ρ Perform check using the board's labels. The servomotors (2) of the pellet box must be switched to the "R" position!

The servomotors are ready to plug in and are connected to the board. All necessary plug clips are included in delivery with the pellet box.

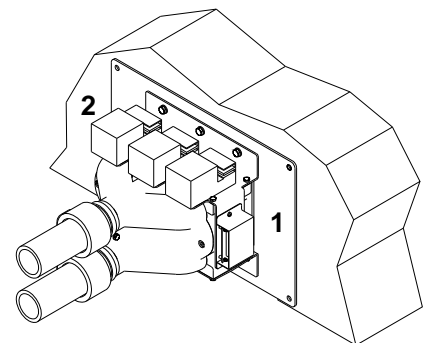

7 Setting protocol

The following tables record which heating components are allocated to the connections. Below the heating circuit number it notes the heating area, for which this heating circuit is used. In addition to the pumps or sensors the relevant connected unit can be noted.

Example: Module address = 2;

First heating circuit: 07	Pump 2.1	<u>Χολεχτορ πυμπ</u>
<u>Ωορκσηοπ ραδιατορ</u>	Sensor 2.1	<u>Χολεχτορ σεנסορ</u>

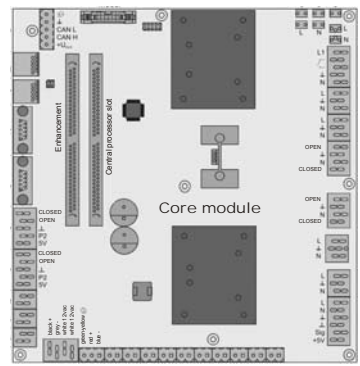
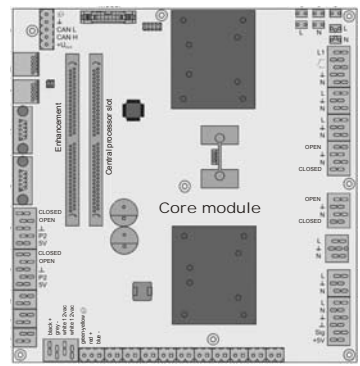
	Core module	
	First heating circuit: 01 _____ _____	Connection heating circuit pump 0 as burner relays Heating circuit pump 0 _____
	Second heating circuit: 02	
	_____ _____	Pump 1 used as return feed lift pump Pump 1 output as switch valve (boiler 1 - boiler 2) Pump 1 as _____

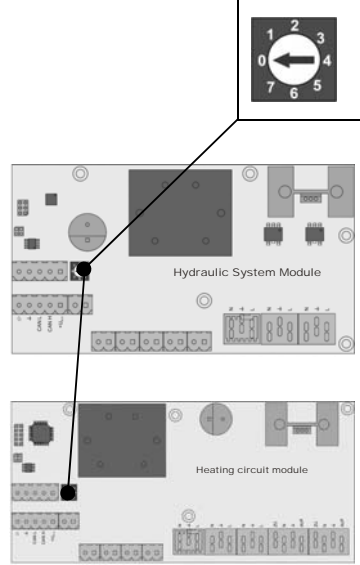
	Set module address: 0	
	Heating circuit module	Hydraulic System Module
	First heating circuit: 03 _____ _____	Pump 0.1 _____ Pump 0.2 _____ Sensor 0.1 _____ Sensor 0.2 _____
	Second heating circuit: 04 _____ _____	Sensor 0.3 _____ Sensor 0.4 _____ Sensor 0.5 _____ Sensor 0.6 _____

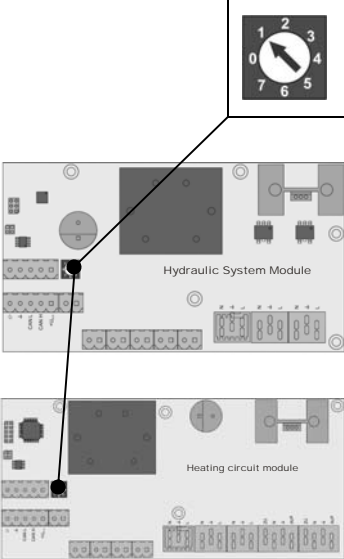
	Set module address: 1	
	Heating circuit module	Hydraulic System Module
	First heating circuit: 05	Pump 1.1 _____ Pump 1.2 _____ Sensor 1.1 _____ Sensor 1.2 _____
	Second heating circuit: 06	Sensor 1.3 _____ Sensor 1.4 _____ Sensor 1.5 _____ Sensor 1.6 _____

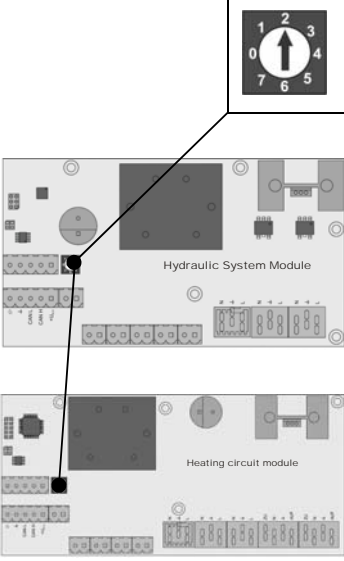
	Set module address: 2	
	Heating circuit module	Hydraulic System Module
	First heating circuit: 07	Pump 2.1 _____ Pump 2.2 _____ Sensor 2.1 _____ Sensor 2.2 _____
	Second heating circuit: 08	Sensor 2.3 _____ Sensor 2.4 _____ Sensor 2.5 _____ Sensor 2.6 _____

Final check	Bus cable correctly connected Addressing correctly carried out and recorded Jumper placed at the last module
-------------	--

8 Index Directory

A	
Automatic mode	16
Modes	16
B	
Boiler	
Changing air settings	42
Changing Lambda settings	44
Display current values	28
General settings	44
Service parameters	29
Setting chamber delivery unit	43
Setting flue gas temperatures	41
Setting pellet loading	43
Setting temperatures	28, 41
C	
Changing languages	47
Changing the date	47
Changing the Operating Level	12
Changing the time	47
Circulation pump	
Display current values	36
Setting temperatures	36
Circulation pump	
Service parameters	37
Configuring the Boiler Release	53
Connecting the Flue Gas Sensor	51
Connecting the remote control	52
Connection layout	
Hydraulic system module	55
Pellet module	56
Pellet module expansion	57
Connection layout	
Core module	50
Heating circuit module	54
Control	
Function Keys	8
Navigation keys	7
Overview	7
Status LED	7
Symbols on the display	10
Control bus	
Connecting the bus cable	58
Setting end jumper	59
Setting module address	58
Setting protocol	60
Controlling the Oil Burner	52
D	
DHW tank	
Display current values	22
Setting heating times	See time window
Setting temperatures	22
DHW tanks	
Service parameters	23

Difference regulator	
Display current values	34
Setting temperatures	34
Difference regulator	
Service parameters	35
Display external temperature	20, 45
Display info text	9
Display service hours	45
Display software version	45
Displays	
Operating rights	46
Domestic water tank	See DHW tank

E	
Error	See Troubleshooting
Error message switch	53

F	
Fuel	
Service parameters	31
Setting Filling Times	31

H	
Heating circuit	
Display current values	20
Service parameters	21
Set times	See time window
Heating circuits	
Setting the temperature	20
Hydraulic system selection	14

I	
Ignition	
Setting ignition times	42
Initial startup	
before heating up for the first time	14
Check drives	14
Check sensors	15
Start system	16

L	
Loading standard settings	48

M	
Mains connection	51
Manual operation	
Testing analogue outputs	39
Testing digital inputs	40
Testing digital outputs	38

Menus	
Boiler	28
Boiler 2	30
Circulation pump	36
Difference regulator	34

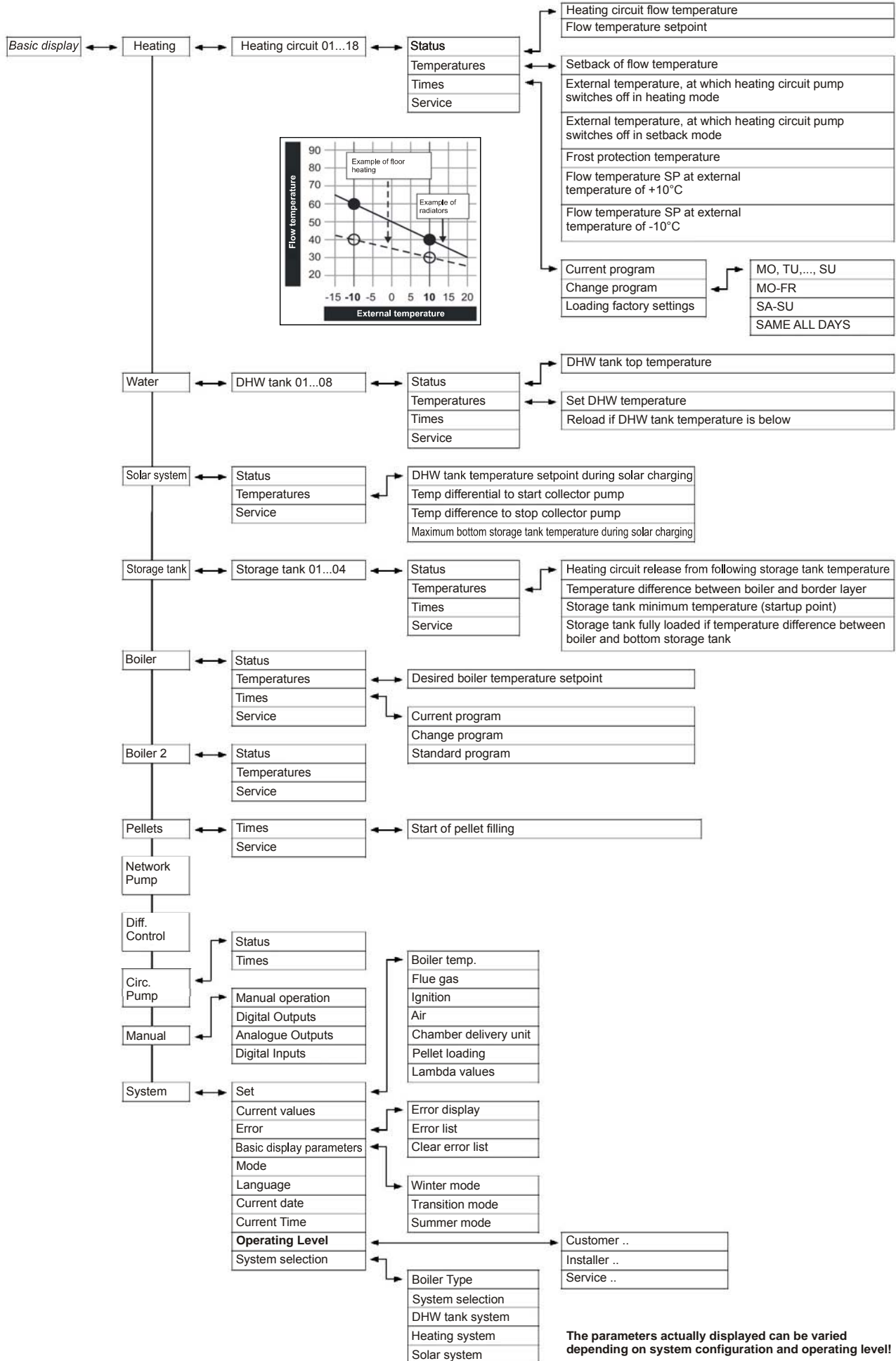

The parameters actually displayed can be varied depending on system configuration and operating level!